

HEICC-2301T

1080p 30x Zoom Explosion-Proof IP Camera

Honeywell's latest explosion-protected network camera is a good fit for onshore, offshore, marine, and heavy industrial installations in hazardous and challenging environments. The camera features a 316L stainless steel housing certified for hazardous areas according to ATEX. The housing prevents any interior sparks or explosions from escaping and igniting the gases or dust in the surrounding air. The HEICC-2301T camera provide extremely crisp video with up to 2 million effective pixels, 30x optical zoom, and True Day/Night WDR for continuous surveillance in both hazardous and safe area applications.



*Images/Certifications/logo for illustration purpose only.

Explosion-Proof Certification

- ATEX certified with AISI 316L stainless steel construction
- Certifications for use in Gas Zone 1 & 2 (Class II A, IIB, IIC, T1-T6 group) and Dust Zone 21 & 22
- Certified temperature for explosion-proof applications: -40°C to 60°C (-40°F to 140°F)
- M25×1.5 threaded hole for use of cable glands or conduit
- IP68 rating guarantees complete protection against harsh weather

Flexible Surveillance Solution

- 1080p 60 fps and 30x optical zoom lens for the flexibility to clearly view the target area with desired depth of view
- H.265, H.264 and MJPEG codec, triple stream support
- Support for unicast and multicast mode for streaming
- ONVIF Profile S and Q compliant
- Supports face detection, real-time intrusion detection and unauthorized loitering detection* analytics
- Security features include individual signed certificates and data encryption

FEATURES AND BENEFITS

- 4.5–135 mm, F1.6–F4.4, 30x optical zoom lens
- 1/2.8" progressive scan image sensor
- Excellent low light performance with down to 0.0005 lux B/W
- Up to 50/60 fps primary stream. Up to 25/30 fps secondary streams
- Up to triple stream support
- Electronic image stabilizer (EIS)
- True WDR: 120 dB
- Multiple, selectable compression formats (H.265/H.264/MJPEG)
- Support for Face detection, ADPRO IntrusionTrace* and ADPRO LoiterTrace*
- Tempered glass
- Global language support with web GUI and online help in 15 languages
- Installation environment temperature: -40°C to 60°C (-40°F to 140°F)
- 100~240V AC power input
- Cyber security hardware chipset built-in
- ONVIF profile S and Q compliant
- Water resistant IP68 ingress protection rating

Easy to Install and Use

- 100~240V AC power input
- Built-in heater
- Integrated sunshield, wiper and optional washer system operated from the web client or special system preset
- 10 m multi-polar cable with barrier cable gland (ATEX certified) and cable tail with conduit cable gland
- Wide range of mounting options
- Remote configuration, motorized zoom adjustments and auto focus through web client

MARKET OPPORTUNITIES

The camera features stainless steel housing and offers full HD resolution image quality. They are ideally suited for video surveillance monitoring of onshore, offshore, marine, and heavy industrial environments, such as the oil and gas industries, as well as dusty environments, such as the paper and textile industries.

HEICC-2301T

1080p 30x Zoom Explosion-Proof IP Camera

FEATURES CONTINUED

The camera can be configured to automatically detect and respond to events such as motion in the scene, alarm inputs, network failure, and/or camera tampering. Automated responses include: sending a notification through email, FTP, and/or HTTP; and sending a still image of the event through email and/or FTP. Setup can be done through a web client.

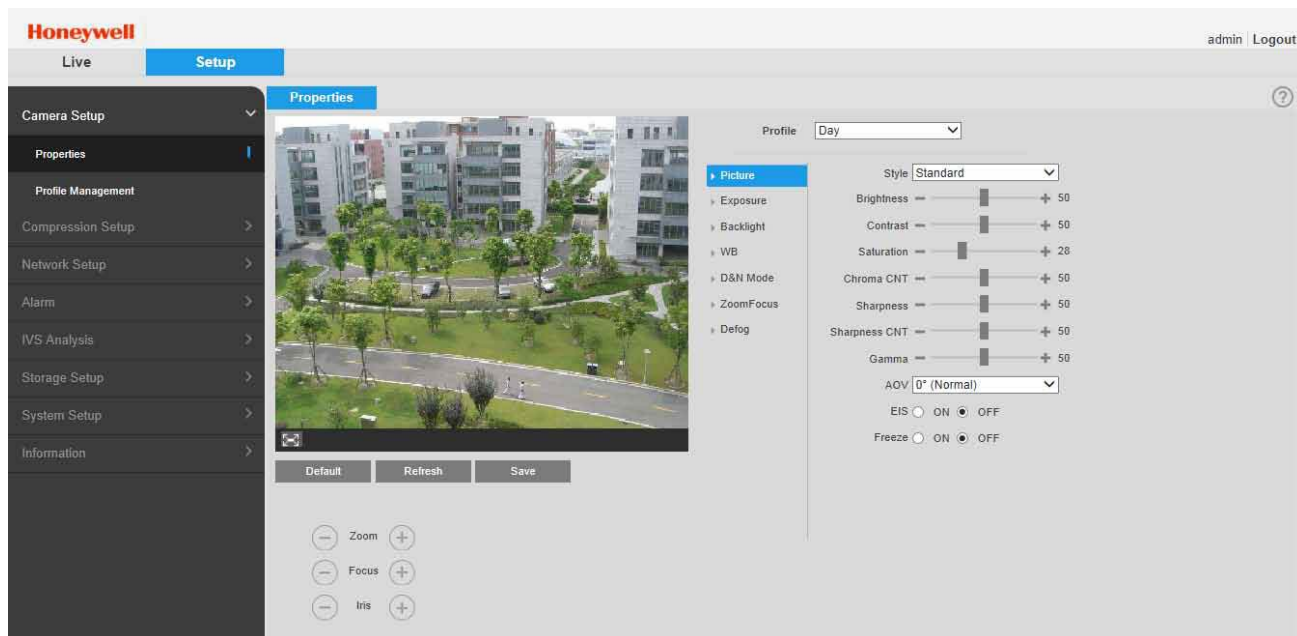

DIMENSIONS

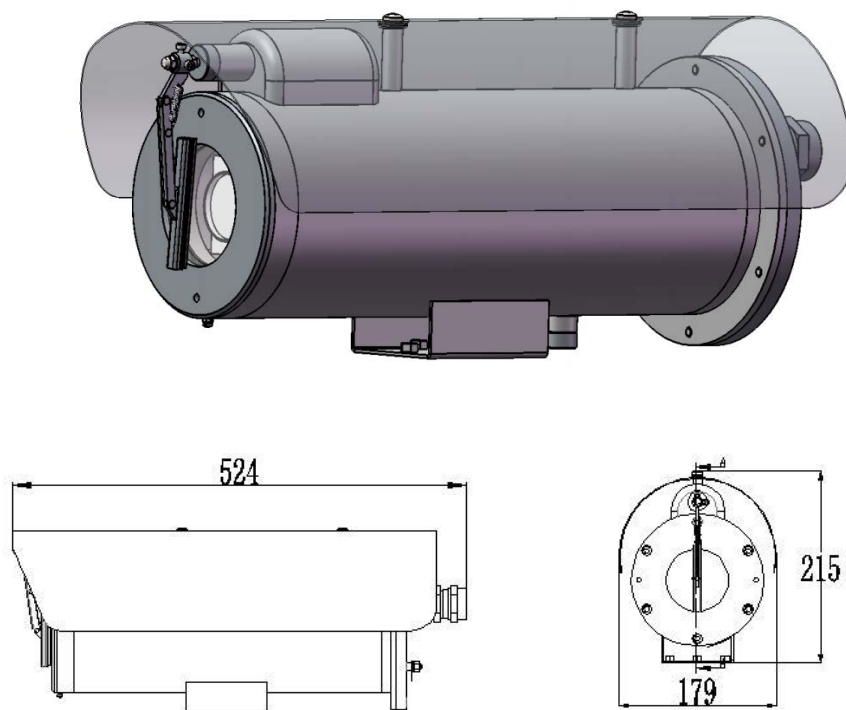

HEICC-2301T

1080p 30x Zoom Explosion-Proof IP Camera

Technical Specifications

CAMERA	
IMAGE SENSOR	1/2.8" Sony Progressive CMOS
OPTICAL ZOOM	30x
DIGITAL ZOOM	16x
NUMBER OF PIXELS (H×V)	1920 × 1080 (1080p)
WDR	120 dB
S/N RATIO	≥ 55 dB (AGC off)
MINIMUM ILLUMINATION	0.0187 lux (color)/0.012 lux (B/W) @ F1.6, 30 IRE, 1/30 0.0547 lux (color)/0.0348 lux (B/W) @ F1.6, 50 IRE, 1/30 0.005 lux (color)/0.0005 lux (B/W) @ F1.6, long exposure
FOCAL LENGTH	4.5 mm - 135 mm
MAX APERTURE	F1.6 - F4.4
FOCUS MODE	Manual/Auto/Semiauto/PTZ Trigger
MICRO SD CARD ¹	Up to 64GB Micro SD card (card not included)
ANGLE OF VIEW	H: 62.35° - 2.53°; V: 37.87° - 1.79°
WHITE BALANCE	Auto/Indoor/Outdoor/ATW/Manual/ Outdoor Auto/ Sodium Lamp Auto/ Sodium Lamp
EXPOSURE MODE	Iris Priority/Shutter Priority/Gain Priority/Manual
BACKLIGHT COMPENSATION	BLC/HLC/WDR (120 dB)
ELECTRONIC SHUTTER	1/1 to 1/30,000 sec
ELECTRONIC IMAGE STABILIZATION	On/Off
DEFOG	On/Off
DAY/NIGHT	Auto/Color/BW
IR CUT FILTER	Auto/Manual
OPERATIONAL	
PRIVACY MASKS	24
MOTION DETECTION	On/Off
IMAGE ROTATION	Flip
AUTO RESUME AFTER POWER FAILURE	Auto
ANALOG VIDEO OUT	Yes

VIDEO ANALYTICS	ADPRO IntrusionTrace2, ADPRO LoiterTrace2, Face Detection
EVENT NOTIFICATION	Record to FTP, Relay output, Email, Preset, Tour, Snapshot
WEB LANGUAGES SUPPORTED	English, Arabic, Czech, Dutch, French, German, Italian, Japanese, Korean, Polish, Portuguese, Russian, Simplified Chinese, Spanish, Turkish

ELECTRICAL	
POWER SOURCE	100~240V AC, 75W Min
POWER CONSUMPTION	Max 3.0A, 50/60 Hz

MECHANICAL	
DIMENSIONS	524 x 215 x 179mm
WEIGHT	Product: 14 kg; Package: 16kg
HOUSING	AISI 316L Stainless Steel Construction
SUNSHIELD	Yes
WIPER	Yes
THREADED HOLE	M25 x 1.5
CONNECTORS	Power input: 3-pin Network: RJ45 connector Alarm I/O: 1/1 (washer control) Audio I/O: 1-way input, 1-way output

CERTIFICATIONS/ENVIRONMENTAL ⁴	
OPERATING TEMPERATURE	-40°C to 60°C (-40°F to 140°F), Cold start -40°C (-40°F)
RELATIVE HUMIDITY	Upto 95%,
WATERPROOF STANDARD	IP68
ATEX	II 2 G Ex db op is IIC T6 Gb II 2 D Ex tb op is IIIC T80° C Db

IP SPECIFICATIONS	
VIDEO COMPRESSION	H.265 / H.264 / MJPEG
VIDEO STREAMING	Primary Stream: 1080p up to 60/50 fps; 1.3M/720p up to 30/25 fps 2nd Stream: 1080p/1.3M/720p up to 30/25 fps 3rd Stream: D1/CIF up to 30/25 fps
VIDEO RESOLUTION	Up to 1080p (1920×1080p)
INTERFACE	RJ-45, 10/100 Mbps Ethernet

HEICC-2301T

1080p 30x Zoom Explosion-Proof IP Camera

SUPPORTED PROTOCOLS ³	IPv4/v6, TCP/IP, UDP, RTP, RTSP, HTTP, HTTPS, SSL, ICMP, FTP, SMTP, DHCP, PPPoE, UPnP, IGMP, SNMP, Bonjour, DNS, DDNS, IEEE 802.1x, QoS, NTP, IP Filter, ONVIF, RS485, Pelco P, Pelco D
SECURITY	Multiple user access levels with enhanced password policy, IP filtering, IEEE 802.1x, Strong Digest authentication for Access permission, HTTPS, TLS1.2 only; high strength encrypted algorithm AES-256, SSH/Telnet closed and FTP disabled to reduce surface being attacked, PCI-DSS compliant, built-in cybersecurity hardware chipset
MAXIMUM USERS ACCESS	20 users
SUPPORTED WEB BROWSERS	Internet Explorer® (11.0+), Firefox, Chrome
SUPPORTED OS	Windows® 7 32-bit/64-bit
COMMUNICATION	ONVIF Profile S and Q

REGULATORY ⁴	
ATEX	EN 60079-0:2012/A11:2013, EN 60079-1:2014, EN 60079-31:2014 and EN 60079-28:2015.

1. Micro SD Card functionality is supported and optional with pre-fitted card from factory only. Micro SD card failure is not covered under standard warranty
2. ADPRO® IntrusionTrace™ and ADPRO LoiterTrace™ are Xtralis® video content analytics products. Additional license purchase(s) required. See <http://www.xtralis.com/analytics> for more information.
3. Some development may be required in specific user cases to support some of these protocols in the field as they mature over time.
4. At the time of this publication, some certifications are pending. Consult the Honeywell representative for the current status of certifications.

RECOMMENDED ACCESSORIES

SYSTEM INTEGRATION

ONVIF support and open API software integration. Refer to www.onvif.org for the ONVIF specification and the Honeywell Open Technology Alliance website (<http://www.security.honeywell.com/hota/>) to learn more about our open and integrated solutions.



HONEYWELL DEVICE INTEGRATION

MAXPRO® NVR FAMILY	Entry to Enterprise Level Network Video Recorders (version 5.6 and greater)
MAXPRO® VMS FAMILY	Entry to Enterprise Level Network Video VMS (version R560 and greater)

ACCESSORIES

HEPHE-WM	316L Stainless Steel Wall Mount Bracket
HEPHE-CM	316L Stainless Steel Corner Mount Bracket
HEIGLAND	Cable Gland
HEI-FT-1.5	1.5m Flexible Tube
HEI-FT-1.0	1m Flexible Tube
HEI-JB	Ex-proof Junction box
HEI-OTB	OFC trans-receiver box

Note: The new HEI Series accessories are not compatible with old Honeywell Explosion Proof cameras. Accessories to be ordered separately with camera



ORDERING

HEICC-2301T	Network Explosion-Proof IP Camera, ATEX, 1/2.8" CMOS, 1080p Resolution, 30x Zoom, WDR, 4.5–135 mm MFZ, H.265/H.264, with Wiper, IP68, 220 VAC, -40°C to 60°C
-------------	--

For more information,
<https://honeywellbuildings.in>
 Call : +91 124 4975000
 Email: HBT-Indiabuildings@honeywell.com

Honeywell HBT India Buildings
 Unitech Trade Center, 5th Floor, Sector-43,
 Block C, Sushant Lok Phase - I,
 Gurugram - 122 002
 Haryana India

www.honeywell.com

© 2020 Honeywell International Inc.

HEICC-2301T
1080p 30x Zoom Explosion-Proof
IP Camera

Honeywell