

NFS2-3030

Intelligent Addressable Fire Alarm System



Intelligent Fire Alarm Control Panels

General

The **NFS2-3030** is an intelligent Fire Alarm Control Panel designed for medium- to large-scale facilities. Fire emergency detection and evacuation are extremely critical to life safety, and the NFS2-3030 is ideally suited for these applications. The NFS2-3030 is part of the ONYX® Series of products from NOTIFIER.

The NFS2-3030 is ideal for virtually any application because it features a modular design that is configured per project requirements. With one to ten Signaling Line Circuits (SLCs), the NFS2-3030 supports up to 3,180 intelligent addressable devices.

Information is critical to fire evacuation personnel, and the NFS2-3030's large 640-character Liquid Crystal Display (LCD) presents vital information to operators concerning a fire situation, fire progression, and evacuation details.

A host of other options are available, including single- or multi-channel voice; firefighters telephone; LED, LCD, or PC-based graphic annunciators; fire or integration networking; advanced detection products for challenging environments, and many additional options.

Features

- Listed to UL Standard 864, 9th edition.
- One to ten isolated intelligent Signaling Line Circuits (SLC) Style 4, 6 or 7.
- Up to 159 detectors (any mix of ion, photo, laser photo, thermal, or multi-sensor) and 159 modules (N.O. manual stations, two-wire smoke, notification, or relay) per SLC. 318 devices per loop/3180 per FACP or network node.
- Large 640-character LCD backlit display (16 lines x 40 characters) or display-less (a node on a network).
- Network option – supports NFS-640, NFS-3030, NFS2-3030, AFP-200, AFP-300/400, AFP1010, AM2020, NCS Network Control Station, or NCA-2 Network Annunciator.
- Built-in Alarm, Trouble, Security, and Supervisory relays.
- **VeriFire® Tools** online/offline program option.
- Application code is saved in Flash memory, eliminating the need to change EPROMs.
- Built-in Degraded Mode option. In the event of a CPU failure, the system is capable of general alarm if a fire condition is present.
- Weekly Occupancy Schedules allow changing sensitivity by time of day and day of week.
- Optional universal 2040-point DACT.
- EIA-485 annunciators, including custom graphics.
- History file with 4000-event capacity in nonvolatile memory, plus separate 1000-event alarm-only file.
- Advanced history filters allow sorting by event, time, date, or address.
- Alarm Verification selection per point, with tally.
- Autoprogramming and Walk Test reports.
- Positive Alarm Sequence (PAS) Presignal.
- Silence Inhibit and Auto Silence timer options.
- Field-programmable on panel or on PC, with **VeriFire Tools** program, also check, compare.
- Non-alarm points for lower priority functions.

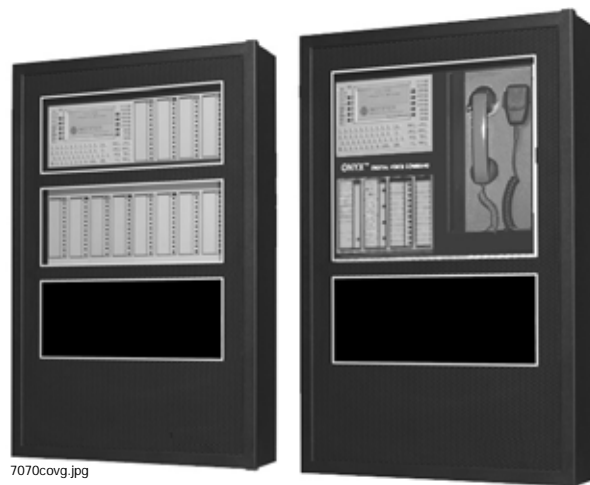

NFS2-3030s, DVC audio option at right

- Remote ACK/Signal Silence/System Reset/Drill via monitor modules.
- Powerful Boolean logic equations — 1000!
- Supports SCS Series smoke control system in both HVAC or FSCS modes.
- EIA-232 printer port.
- EIA-485 annunciator port.

640-CHARACTER DISPLAY FEATURES:

- Backlit, 640-character display.
- Program keypad: full QWERTY keypad.
- Up to nine users, each with a password and selectable access levels.
- **11 LED indicators:** Power; Fire Alarm; Pre-Alarm; Security; Supervisory; System Trouble; Other Event; Signals Silenced; Point Disabled; CPU Failure; Controls Active.
- **Membrane Switch Controls:** Acknowledge; Signal Silence; Drill; System Reset; Lamp Test.
- **LCD Display:** 640 characters (16 x 40) with long-life LED backlight.

FLASHSCAN™ INTELLIGENT FEATURES:

- Poll 318 devices on each loop in less than two seconds.
- Activate up to 159 outputs in less than five seconds.
- Multicolor LEDs blink device address during Walk Test.
- Fully digital, high-precision protocol (U.S. Patent 5,539,389).
- Manual sensitivity adjustment — nine levels.
- Pre-alarm ONYX intelligent sensing — nine levels.
- Sensitivity windows:
 - Ion – 0.5 to 2.5%/foot obscuration.
 - Photo – 0.5 to 2.35%/foot obscuration.
 - Laser (VIEW®) – 0.02 to 2.0%/foot obscuration.
 - Acclimate Plus™ – 0.5 to 4.0%/foot obscuration.
 - HARSH™ – 0.5 to 2.35%/foot obscuration.
- Drift compensation (U.S. Patent 5,764,142).

- Multi-detector algorithm involves nearby detectors in alarm decision (U.S. Patent 5,627,515).
- Automatic detector sensitivity testing.
- Maintenance alert (two levels).
- Self-optimizing pre-alarm.
- Programmable activation of sounder/relay bases during alarm or pre-alarm.
- Read Status displays the level of detector cleanliness.

VIEW® (VERY INTELLIGENT EARLY WARNING) SMOKE DETECTION TECHNOLOGY:

- Revolutionary spot laser design.
- Advanced ONYX intelligent sensing algorithms differentiate between smoke and non-smoke signals (U.S. Patent 5,831,524).
- Addressable operation pinpoints the fire location.
- No moving parts to fail or filters to change.
- Early warning performance comparable to the best aspiration systems at a fraction of the lifetime cost.

ACCLIMATE PLUS™ LOW-PROFILE INTELLIGENT MULTI-SENSOR:

- Detector automatically adjusts sensitivity levels without operator intervention or programming. Sensitivity increases with heat.
- Microprocessor-based technology; combination photo and thermal technology.
- Low-temperature signal at 40°F ± 5°F (4.44°C ± 2.77°C).

HARSH™ HOSTILE-AREA SMOKE HEAD:

- Provides early warning of smoke detection in environment where traditional smoke detectors are not practical.

- The detector's filters remove particulates down to 30 microns in size.
- Intake fan draws air into photo chamber, while airborne particles and water mist are removed.
- Requires auxiliary 24 VDC from system or remote power supply.

RELEASING FEATURES:

- Ten independent hazards.
- Sophisticated cross-zone (three options).
- Delay timer and Discharge timers (adjustable).
- Abort (four options).

VOICE AND TELEPHONE FEATURES:

- Solid state message generation.
- Hard-wired voice control module options.
- Firefighter telephone option.
- 30- to 120-watt high-efficiency amplifiers (AA Series).
- Backup tone generator and amplifier option.
- Multichannel voice transponder (XPIQ).

FlashScan® Exclusive New World-Leading Detector Protocol

At the heart of the NFS2-3030 is a set of detection devices and device protocol — FlashScan (U.S. Patent 5,539,389). FlashScan is an all-digital protocol that gives superior precision and high noise immunity.

As well as giving quick identification of an active input device, this new protocol can also activate many output devices in a fraction of the time required by competitive protocols. This high speed also allows the NFS2-3030 to have the largest device per loop capacity in the industry — 318 points — yet every input and

Sample System Options

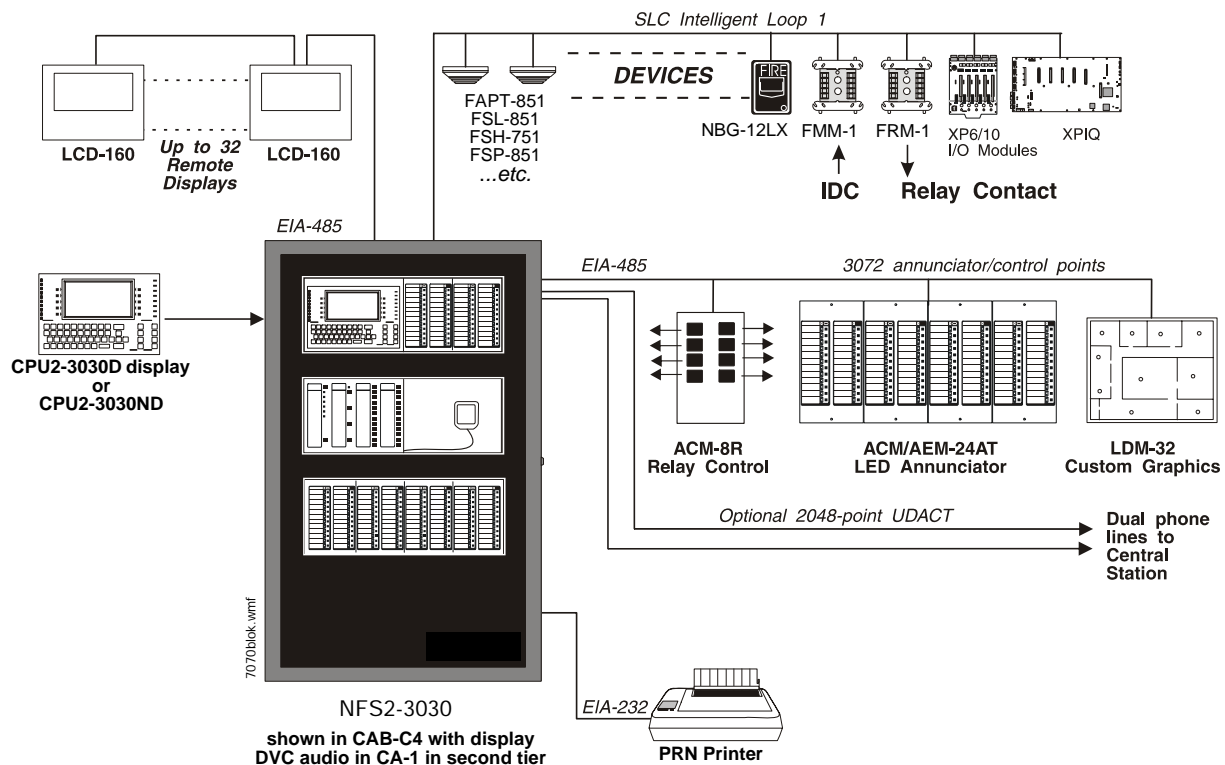

output device is sampled in less than two seconds. The micro-processor-based FlashScan® detectors have bicolor LEDs that can be coded to provide diagnostic information, such as device address during Walk Test.

ONYX INTELLIGENT SENSING

ONYX Intelligent Sensing is a set of software algorithms that provide the NFS2-3030 with industry-leading smoke detection capability. These complex algorithms require many calculations on each reading of each detector, and are made possible by the very high-speed microcomputer used by the NFS2-3030.

Drift Compensation and Smoothing. Drift compensation allows the detector to retain its original ability to detect actual smoke, and resist false alarms, even as dirt accumulates. It reduces maintenance requirements by allowing the system to automatically perform the periodic sensitivity measurements required by NFPA Code 72. Smoothing filters are also provided by software to remove transient noise signals, usually caused by electrical interference.

Maintenance Warnings. When the drift compensation performed for a detector reaches a certain level, the performance of the detector may be compromised, and special warnings are given. There are three warning levels: (1) Low Chamber value, usually indicative of a hardware problem in the detector; (2) Maintenance Alert, indicative of dust accumulation that is near but below the allowed limit; (3) Maintenance Urgent, indicative of dust accumulation above the allowed limit.

Sensitivity Adjust. Nine sensitivity levels are provided for alarm detection. These levels can be set manually, or can change automatically between day and night. Nine levels of pre-alarm sensitivity can also be selected, based on predetermined levels of alarm. Pre-alarm operation can be latching or self-restoring, and can be used to activate special control functions.

Self-Optimizing Pre-Alarm. Each detector may be set for "Self-Optimizing" pre-alarm. In this special mode, the detector "learns" its normal environment, measuring the peak analog readings over a long period of time, and setting the pre-alarm level just above these normal peaks.

Cooperating Multi-Detector Sensing. A patented feature of ONYX Intelligent Sensing is the ability of a smoke sensor to consider readings from nearby sensors in making alarm or pre-alarm decisions. Without statistical sacrifice in the ability to

resist false alarms, it allows a sensor to increase its sensitivity to actual smoke by a factor of almost two to one.

Field Programming Options

Autoprogram is a timesaving feature of the NFS2-3030. It is a special software routine that allows the NFS2-3030 to "learn" what devices are physically connected and automatically load them in the program with default values for all parameters. Requiring less than one minute to run, this routine allows the user to have almost immediate fire protection in a new installation, even if only a portion of the detectors are installed.

Keypad Program Edit. The NFS2-3030, like all NOTIFIER intelligent panels, has the exclusive feature of program creation and editing capability from the front panel keypad, while continuing to provide fire protection. The architecture of the NFS2-3030 software is such that each point entry carries its own program, including control-by-event links to other points. This allows the program to be entered with independent per-point segments, while the NFS2-3030 simultaneously monitors other (already installed) points for alarm conditions.

VeriFire® Tools is an offline programming and test utility that can greatly reduce installation programming time, and increase confidence in the site-specific software. It is Windows® based and provides technologically advanced capabilities to aid the installer. The installer may create the entire program for the NFS2-3030 in the comfort of the office, test it, store a backup file, then bring it to the site and download from a laptop into the panel.

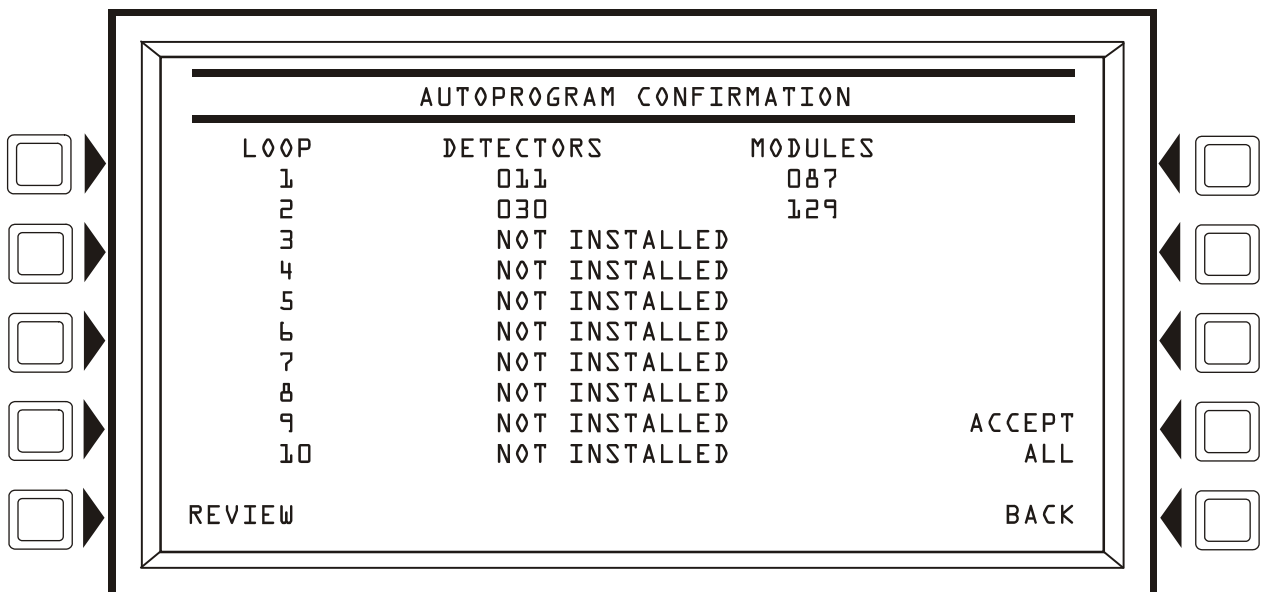

6880prog.wmf

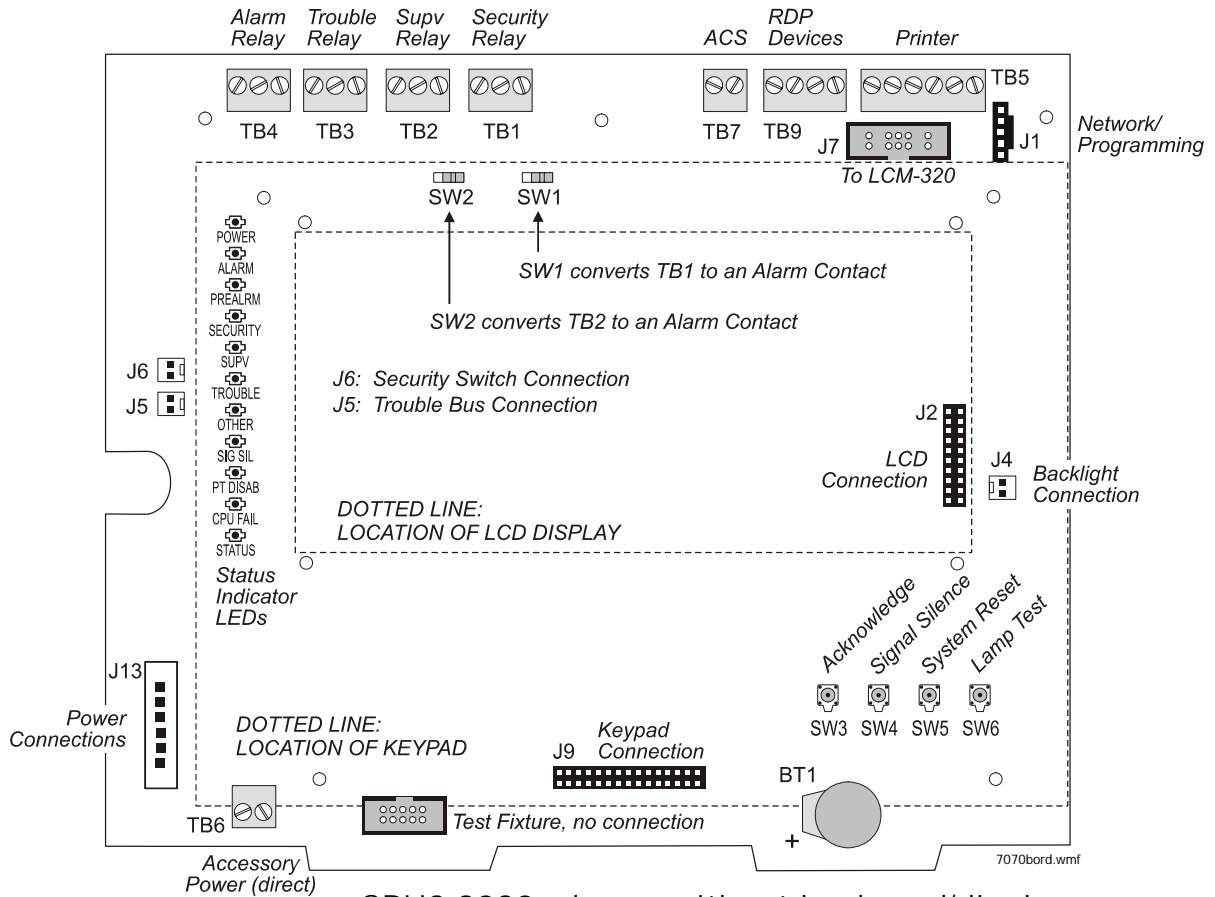

CPU2-3030, shown without keyboard/display

The control panel electronics are contained on one printed circuit board (PCB) that holds the central processing unit (CPU2-3030). The CPU2-3030 can be purchased with or without keypad and display; connections are identical on both versions. Diagram shows location of connections, switches, jumpers, and LEDs on the circuit board.

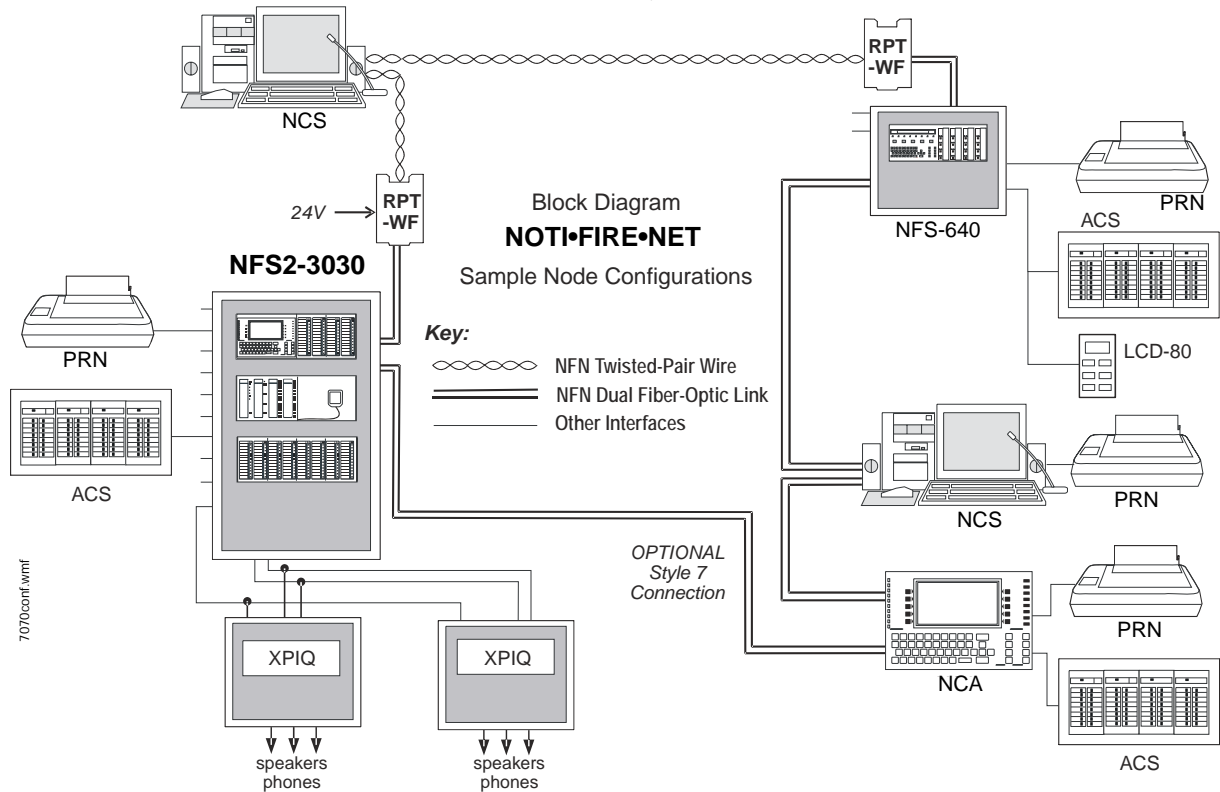

Placement of Equipment in Chassis and Cabinet

The following guidelines outline the NFS2-3030's flexible system design.

Rows: The first row of equipment in the cabinet mounts in chassis **CHS-M3**. Mount the second, third, or fourth rows of equipment in chassis **CHS-4MB** (see *NFS2-3030 Installation Manual* regarding panel output modules) or CHS-4L (for voice components, see the *DAA and DVC Voice Alarm System Manuals*).

Wiring: When designing the cabinet layout, consider separation of power-limited and non-power-limited wiring as discussed in the *NFS2-3030 Installation Manual*.

Positions: A chassis offers four basic side-by-side positions for components; the number of modules that can be mounted in each position depends on the chassis model and the size of the individual module. There are a variety of standoffs and hardware items available for different combinations and configurations of components.

It is critical that all mounting holes of the NFS2-3030 are secured with a screw or standoff to ensure continuity of Earth Ground.

Layers: The CPU2-3030 mounts in chassis CHS-M3 in the top row of the cabinet. The CPU2-3030 and its optional display occupy the left half of the chassis (positions 1 and 2). If NCA-2 is used, it may be door-mounted in front of a displayless CPU2-3030ND. The right half (positions 3 and 4) of CHS-M3 can hold up to four layers of equipment including annunciators and option boards. The BMP-1 Blank Module Plate covers unused positions and also provides a location to door-mount some option boards. Second, third, and fourth tiers of equipment use any chassis compatible with CAB-4 Series backboxes, such as the CHS-4MB. Some equipment, such as the NCA-2 and annunciators, can be door-mounted; refer to equipment documentation for details.

Expansion: Loop Control Module LCM-320 adds SLC loops to the NFS2-3030; the Loop Expander Module LEM-320 expands an LCM-320; adding another loop. The NFS2-3030 supports up to five LCMs and up to five LEMs. Other option boards include the NCM-W, NCM-F, and the TM-4.

PRODUCT LINE INFORMATION

- Configuration Guidelines
- Network Options
- Power Supplies
- Audio Options
- Compatible Devices, EIA-232 Ports
- Compatible Devices, EIA-485 Ports
- Compatible Intelligent Devices
- Other Options

CONFIGURATION GUIDELINES

Stand-alone and network systems require a main display. On single-CPU systems (one NFS2-3030), the display option is the CPU2-3030D. On network systems (two or more NFS2-3030s and/or NFS-640s), at least one NCA-2 or NCS annunciation device is required. Options listed as follows:

CPU2-3030D:NFS2-3030 Primary Display. CPU2-3030D ships with keypad/display installed; includes 640-character backlit LCD display, QWERTY programming and control keypad. CPU2-3030 is a central processing unit and requires an **AMPS-24(E)** power supply.

CPU2-3030ND:CPU2-3030 without display.

VeriFire-TCD: **VeriFire® Tools** CD-ROM. Contains programming software for the NFS2-3030, NFS-640, NCA-2, and XPIQ. Includes local panel connection cable. Programming PC requires a serial port connection. See *DN-6871*.

LCM-320:Loop Control Module. Adds SLCs to 3030; 3030 supports up to 5 LCM-320s and 5 LEM-320s. See *DN-6881*.

LEM-320:Loop Expander Module. Expands each LCM used on the 3030. See *DN-6881*.

CHS-M3:Mounting chassis for CPU2-3030. One required for each CPU2-3030D/3030ND.

DP-DISP:Dress panel for top row in cabinet with CPU2-3030D installed.

BMP-1:Blank module for unused module positions.

JBP2-4:Battery plate, required.

SAMPLE SYSTEM: *Four-loop NFS2-3030 with display:* CPU2-3030D, DP-DISP, two BMP-1s, CHS-M3, two LCM-320s, two LEM-320s, AMPS-24, SBB-A4, DR-A4, BP2-4, BB-100, batteries.

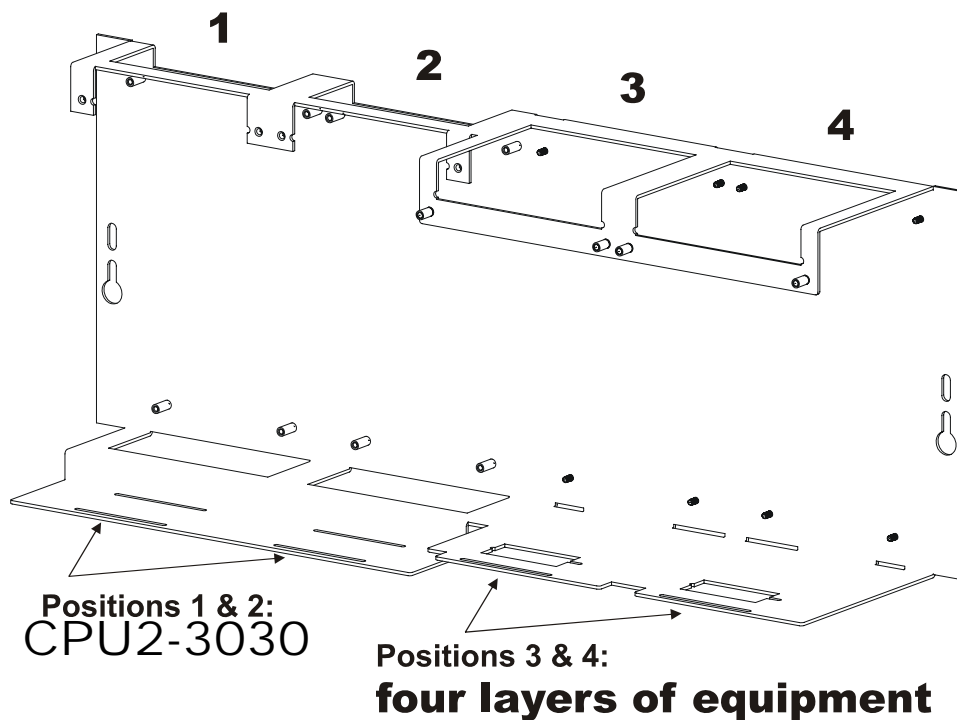

NETWORK OPTIONS

NCA-2:Network Control Annunciator, 640 characters. An alternate primary display for CPU2-3030 can be provided by the NCA-2 or the NCS. Using NCA-2 as primary display enables non-English languages. On network systems (two or more CPU2-3030/3030s), one network display (either NCA-2 or NCS) is required for every system. On network systems, the NCA-2 connects (and requires) an NCM network communications module. Mounts in a row of FACP node or in two annunciator positions. Mounting options include the DP-DISP, ADP-4B, or in an annunciator box, such as the ABS-2D. In CAB-4 top-row applications, a DP-DISP and two BMP-1 blank modules are required for mounting. *See DN-6858.*

NCM-W:Network Communications Module, Wire. Order one NCM per network node (CPU2-3030 or NCA-2). *See DN-6861.*

NCM-F:Network Communications Module, Fiber. Order one NCM per network node (CPU2-3030 or NCA-2). *See DN-6861.*

RPT-W:repeater board; wire connection. *See DN-4644.*

RPT-F:repeater board; fiber connection. *See DN-4644.*

RPT-WF:repeater board; allows a change in media type between wire and fiber. *See DN-4644.*

NCS5-W-ONYXNetwork Control Station, Wire. UL-Listed graphics PC with mouse, 17" color flat-screen LCD monitor. Order as necessary for network systems. Each NCS consumes one of 103 network addresses. *See DN-6868 (previous NCS-W), ONYX@DN-6869.*

NCS5-F-ONYXNetwork Control Station, Fiber. UL-Listed graphics PC with mouse, 17" color flat-screen LCD monitor. Order as necessary for network systems. Each NCS consumes one of 103 network addresses. *See DN-6868 (previous NCS-F), ONYX@DN-6869.*

POWER SUPPLIES

AMPS-24(E):One required for each NFS2-3030. Addressable power supply and battery charger with two 24 VDC outputs. Addressable by any FlashScan® or CLIP mode FACP. Charges 25 to 200 AH batteries. Occupies up to four addresses on an SLC, depending on configuration. Primary input power for panel; **AMPS-24:** 120 VAC, 50/60 Hz, 3.0 amps. **AMPS-24E:** 220/240 VAC, 50/60 Hz, 1.5 Amps. *See DN-6883.*

BB-100:Battery and power supply backbox. The BB-100 is used to mount the AMPS-24(E) power supply (the main power supply does not mount in the main cabinet). It also mounts up to two PS-121000 100-AH batteries. 30" (76.20 cm) wide x 25" (63.50 cm) high x 7.5" (19.05 cm) deep; depth includes door.

BB-200:Battery and power supply backbox. The BB-200 is used to mount the AMPS-24(E) power supply (the main power supply does not mount in the main cabinet). It also mounts up to four PS-121000 100-AH batteries. 30" (76.20 cm) wide x 36" (91.44 cm) high x 7.5" (19.05 cm) deep; depth includes door.

NFS-LBB:Battery Box (required for batteries over 25 AH). Dimensions: Box: 24" (610 mm) wide x 14" (356 mm) high x 7.75" (197 mm) deep. Door: 24.125" (613 mm) wide x 14.25" (362 mm) high; door adds 0.0625" (approx. 1.6 mm) to depth.

APS-6R:Auxiliary Power Supply (expander). Provides up to 6.0 amperes of regulated power for compatible Notification appliance circuits. Includes battery input and transfer relay, and over-current protection. Mounts on one of four positions on a CHS-4L or CHS-4 chassis. *See DN-5952.*

ACPS-2406:6.0 amp addressable charger power supply. *See DN-6834.*

FCPS-24:The FCPS-24 is a remote six-amp (four-amp continuous) repeater/power supply. *See DN-5132.*

FCPS-24S6/-24S8:Remote six-amp and eight-amp power supplies with battery charger. *See DN-6927.*

BAT Series:NFS2-3030 utilizes two 12 volt, 12 to 55 AH batteries. *See DN-6933.*

PS Series:NFS2-3030 utilizes two 12 volt, 25 to 200 AH batteries. *See DN-1109.*

AUDIO OPTIONS

DAA-5025: 25 Vrms Digital Audio Amplifier assembly with DAA-PS power supply board, shipped mounted to its chassis. *See DN-7046.*

DAA-5070:70.7 Vrms Digital Audio Amplifier assembly with DAA-PS power supply board, shipped mounted to its chassis. *See DN-7046.*

DP-1B:Dress panel for DAA; covers one tier of CAB-4 Series cabinet. *See DN-7046.*

CHS-BH1:Battery chassis; holds two 12.0 AH batteries. Mounts on the left side of DAA chassis. *See DN-7046.*

DVC:Digital Voice Command, digital audio processor with message storage for up to 16 minutes of standard quality (2 minutes at high quality) digital audio. *See DN-7045.*

DVC-EM:Digital Voice Command, digital audio processor with message storage for up to 32 minutes of standard quality (4 minutes at high quality) digital audio. *See DN-7045.*

DVC-KD:Keypad for local annunciation and controls; status LEDs and 24 user-programmable buttons. *See DN-7045.*

CA-1:Chassis, occupies one tier of a CAB-4 Series enclosure. The left side accommodates one DVC and a DVC-KD (optional); and the right side houses a CMIC-1 microphone and its well (optional). *See DN-7045.*

CA-2:Chassis assembly, occupies two tiers of a CAB-4 Series enclosure. The left side accommodates one DVC mounted on a half-chassis and one NFS2-3030 or NCA-2 mounted on a half-chassis. The right side houses a microphone/handset well. The CA-2 assembly includes CMIC-1 microphone. ADDR Series doors with two-tier visibility are available for use with the CA-2 configuration: ADDR-B4, ADDR-C4, ADDR-D4 (below).

TELH-1:Firefighter's Telephone Handset for use with the DVC when mounted in the CA-2 chassis. *See DN-7045.*

ADDR-B4:Two-tier-sized door designed for use with the CA-2 chassis configuration. ADDR Series doors are similar to CAB-4 Series "DR" doors, but a clear window space exposes the top two tiers of the CAB-4 enclosure. Use an SBB-B4 backbox with the ADDR-B4. *See DN-7045, DN-6857.*

ADDR-C4:Three-tier-sized door designed for use with the CA-2 chassis configuration. ADDR Series doors are similar to CAB-4 Series "DR" doors, but a clear window space exposes the top two tiers of the CAB-4 enclosure. Use an SBB-C4 backbox with the ADDR-C4. *See DN-7045, DN-6857.*

ADDR-D4:Four-tier-sized door designed for use with the CA-2 chassis configuration. ADDR Series doors are similar to CAB-4 Series "DR" doors, but a clear window space exposes the top two tiers of the CAB-4 enclosure. Use an SBB-D4 backbox with the ADDR-D4. *See DN-7045, DN-6857.*

DPA-1:Dress panel, used with the CA-1 chassis when configured with a DVC, DVC-KD, and CMIC-1. *See DN-7045.*

DPA-2:Dress Panel used with the CA-2 chassis assembly.

DPA-1A4:Dress panel, used with the CA-1 chassis when the CMIC-1 is not used. Provides mounting options on right two bays for two ACS annunciators, or for blank plates. *See DN-7045.*

CMIC-1:Microphone used with DVC/DVC-EM. Included with CA-2 chassis assembly. *See DN-7045.*

FTM-1:Firephone Control Module connects a remote firefighter telephone to a centralized telephone console. Reports status to panel. Wiring to jacks and handsets is supervised.

RM-1/RM-1SA:Remote microphone assemblies, mount on ADP-4 (RM-1) dress panel or CAB-RM/-RMR (RM-1SA) stand-alone cabinets. *See DN-6728.*

AA-30:Audio Amplifier, 30 watts. Switch-mode power. Includes amplifier and audio input supervision, backup input, and automatic switchover, power supply, cables. *See DN-3224.*

AA-120/AA-100:Audio Amplifier provides up to 120 watts of 25 Vrms audio power. The amplifier contains an integral chassis for mounting to a CAB-B4, -C4, or -D4 backbox (consumes one row). Switch-mode power. Includes audio input and amplified output supervision, backup input, and automatic switchover to backup tone. Order the AA-100 for 70.7 Vrms systems and 100 watts of power. *See DN-3224.*

XPIQ:The XPIQ quad intelligent voice transponder for distributed multichannel voice evacuation systems, an integrated audio amplification and distribution subsystem controlled by FACP. Capable of playing up to four simultaneous messages. Accepts up to four 25-watt amplifiers. *See DN-6823.*

COMPATIBLE DEVICES, EIA-232 PORTS

PRN-6:80-column printer. See *DN-6956*.

VS4095/S2:Printer, 40-column, 24 V. Order from Keltron, Inc. See *DN-3260*.

COMPATIBLE DEVICES, EIA-485 PORTS

ACM-24AT:ONYX® Series ACS annunciator – up to 96 points of annunciation with Alarm or Active LED, Trouble LED, and switch per circuit. Active/Alarm LEDs can be programmed (by powered-up switch selection) by point to be red, green, or yellow; the Trouble LED is always yellow. See *DN-6862*.

AEM-24AT:Same LED and switch capabilities as ACM-24AT, expands the ACM-24AT to 48, 72, or 96 points. See *DN-6862*.

ACM-48A:ONYX® Series ACS annunciator – up to 96 points of annunciation with Alarm or Active LED per circuit. Active/Alarm LEDs can be programmed (by powered-up switch selection) in groups of 24 to be red, green, or yellow. Expandable to 96 points with one AEM-48A. See *DN-6862*.

AEM-48A:Same LED capabilities as ACM-48A, expands the ACM-48A to 96 points. See *DN-6862*.

ACM-8R:Remote Relay Module with eight Form-C contacts. Can be located up to 6,000 ft. (1828.8 m) from panel on four wires. See *DN-3558*.

LCD-160:Liquid Crystal Display annunciator, 160-character backlit. Can store character sets for multiple languages. Supports Canadian requirements. See *DN-6940*.

RPT-485 Series:Repeats EIA-485 over twisted pair or converts to fiber-optic medium; repeater, isolator and/or fiber-optic modem. See *DN-4737*.

SCS Series:Smoke control station; eight (expandable to 16) circuits. See *DN-4818*.

TM-4:Transmitter Module. Includes three reverse-polarity circuits and one municipal box circuit. Mounts in panel module position (as in single-address mode applications) or in CHS-M3 position. See *DN-6860*.

UDACT:Universal Digital Alarm Communicator Transmitter, 636 channel. See *DN-4867*.

UZC-256:Programmable Universal Zone Coder provides positive non-interfering successive zone coding. Microprocessor-controlled, field-programmable from IBM®-compatible PCs (requires optional programming kit). See *DN-3404*.

COMPATIBLE INTELLIGENT DEVICES

BEAMHK:Heating kit for transmitter/receiver unit of FSB-200(S) below. See *DN-6985*.

BEAMHRK:Heating kit for use with the reflector of FSB-200(S) below. See *DN-6985*.

BEAMLRK:Long-range accessory kit, FSB-200(S) below.

BEAMMRK:Multi-mount kit, FSB-200(S) below.

BEAMSMK:Surface-mount kit, FSB-200(S) below.

FSB-200:Intelligent beam smoke detector. See *DN-6985*.

FSB-200S:Intelligent beam smoke detector with integral sensitivity test. See *DN-6895*.

FSI-851:Low-profile FlashScan® ionization detector, will replace FSI-751. See *DN-6934*.

FSI-751:Low-profile FlashScan® ionization detector. See *DN-6714*.

FSP-851:Low-profile FlashScan® photoelectric detector, will replace FSP-751. See *DN-6935*.

FSP-751:Low-profile FlashScan® photoelectric detector. See *DN-6714*.

FSP-851T:Low-profile FlashScan® photoelectric detector with 135°F (57°C) thermal, will replace FSP-751T. See *DN-6935*.

FSP-751T:Low-profile FlashScan® photoelectric detector with 135°F (57°C) thermal, will replace FSP-751T. See *DN-6714*.

FST-851:FlashScan® thermal detector 135°F (57°C), will replace FST-751. See *DN-6936*.

FST-751:FlashScan® thermal detector 135°F (57°C). See *DN-6716*.

FST-851R:FlashScan® thermal detector 135°F (57°C) with rate-of-rise, will replace FST-751R. See *DN-6936*.

FST-751R:FlashScan® thermal detector 135°F (57°C) with rate-of-rise. See *DN-6716*.

FST-851H:FlashScan® 190°F (88°C) high-temperature thermal detector. See *DN-6936*.

FSD-751P:FlashScan® photo duct detector with housing. See *DN-6821*.

FSD-751PL:Low-flow FlashScan® photo duct detector with housing, will replace FSD-751P. See *DN-6955*.

FSD-751RP:FlashScan® photo duct detector with relay and housing. See *DN-6821*.

FSD-751RPL:Low-flow FlashScan® photo duct detector with relay and housing, will replace FSD-751RPL. See *DN-6955*.

FAPT-851:FlashScan® Acclimate Plus™ low-profile multi-sensor detector, will replace FAPT-751. See *DN-6937*.

FAPT-751:Acclimate Plus™ low-profile multisensor detector. See *DN-6833*.

FSH-751:FlashScan® HARSH™ Hostile Area Smoke Head. See *DN-6875*.

FSL-751:FlashScan® VIEW® laser photo detector, will replace LPX-751. See *DN-6886*.

LPX-751:Low-profile VIEW® laser photo detector. See *DN-5306*.

B224RB:Low-profile relay base.

B224BI:Isolator base for low-profile detectors.

B710LP:Low-profile base. Standard U.S. style.

B501:European-style, 4" (10.16 cm) base.

B501BH:Sounder base, includes B501 base above.

FMM-1:FlashScan® monitor module. See *DN-6720*.

FDM-1:FlashScan® dual monitor module. See *DN-6720*.

FZM-1:FlashScan® two-wire detector monitor module. See *DN-6720*.

FMM-101:FlashScan® miniature monitor module. See *DN-6720*.

FCM-1:FlashScan® NAC control module. See *DN-6724*.

FRM-1:FlashScan® relay module. See *DN-6724*.

FSM-101:FlashScan® pull station monitor module.

NBG-12LX:Manual fire alarm station, addressable. See *DN-6726*.^

ISO-X:Isolator module. See *DN-2243*.

XP Series:Transponder. See *DN-0759*.

XP5-M:FlashScan® transponder, five monitor points. See *DN-6625*.

XP5-C:FlashScan® transponder, five control points or Form-C relays. See *DN-6625*.

XP6-C:FlashScan® six-circuit supervised control module. See *DN-6924*.

XP6-MA:FlashScan® six-zone interface module; connects intelligent alarm system to two-wire conventional detection zone. See *DN-6925*.

XP6-R:FlashScan® six-relay (Form-C) control module. See *DN-6926*.

XP10-M:FlashScan® ten-input monitor module. See *DN-6923*.

XPIQ:Intelligent quad transponder. See *DN-6823*.

OTHER OPTIONS

DPI-232:Direct Panel Interface, specialized modem for extending serial data links to remotely located FACPs and/or peripherals. See *DN-6870*.

CHS-4N:Chassis for mounting up to four APS-6Rs.

CHS-4L:Low-profile four-position Chassis. Mounts two AA-30 amplifiers or one AMG-E and one AA-30.

DP-1B:Blank Dress panel. Provides dead-front panel for unused tiers or to cover AA-30, AA-120, or AMG-E.

CAB-4 Series:The CAB-4 Series cabinets are fabricated from 16-gauge steel with unique full-front LEXAN®, reverse-silk-screened for durability. Cabinets are available in four sizes, "A" through "D", with one to four tiers. A trim ring option is available for semi-flush mounting. Requires BP2-4 battery plate. See *DN-6857*.

SYSTEM SPECIFICATIONS

System Capacity

- Intelligent Signaling Line Circuits1 expandable to 10
- Intelligent detectors 159 per loop
- Addressable monitor/control modules 159 per loop
- Programmable software zones..... over 2000
- ACS annunciators
per CPU2-303032 address x 64 or 96 points

NOTE: The CPU2-3030 can support up to 96 annunciator address points per ACM-24/-48.

Specifications

- **Primary input power: AMPS-24:** 120 VAC, 50/60 Hz, 3.0 amps. **AMPS-24E:** 220/240 VAC, 50/60 Hz, 1.5 Amps.
- **Total output 24 V power:** 4.5 A in alarm.

NOTE: The power supply has a total of 4.5 Amps of available power.

- **General purpose power:** 1.0 A.
- **Battery charger range:** 25 AH – 200 AH. Use separate cabinet for batteries over 25 AH.
- **Float Rate:** 27.6 V.

Temperature and Humidity Ranges

This system meets NFPA requirements for operation at 0 – 49°C/32 – 120°F and at a relative humidity 93% ± 2% RH (noncondensing) at 32°C ± 2°C (90°F ± 3°F). However, the useful life of the system's standby batteries and the electronic components may be adversely affected by extreme temperature ranges and humidity. Therefore, it is recommended that this system and its peripherals be installed in an environment with a normal room temperature of 15 – 27°C/60 – 80°F.

Agency Listings and Approvals

These listings and approvals apply to the modules specified in this document. In some cases, certain modules or applications may not be listed by certain approval agencies, or listing may be in process. Consult factory for latest listing status.

- **UL Listed:** S635
- **ULC Listed:** S635
- **MEA:** 232-06-E
- **CSFM:** 7170-0028:223; 7165-0028:224
- **FM Approved**
- **City of Denver**
- **City of Chicago**
- **PSB Corporation**
- **Fire Services Department (Hong Kong)**

Standards

The NFS2-3030 complies with the following UL Standards and NFPA 72 Fire Alarm Systems requirements:

- **UL 864** (Fire).
- **UL 1076** (Burglary).
- **LOCAL** (Automatic, Manual, Waterflow and Sprinkler Supervisory).
- **AUXILIARY** (Automatic, Manual and Waterflow).
- **REMOTE STATION** (Automatic, Manual and Waterflow).
- **PROPRIETARY** (Automatic, Manual and Waterflow).
- **EMERGENCY VOICE/ALARM.**

Acclimate Plus™, HARSH™, and NOTI•FIRE•NET™ are all trademarks; and FlashScan®, NION®, NOTIFIER®, ONYX®, UniNet®, VeriFire®, and VIEW® are all registered trademarks of Honeywell International Inc. ©2007 by Honeywell International Inc. All rights reserved. Unauthorized use of this document is strictly prohibited.



This document is not intended to be used for installation purposes.
We try to keep our product information up-to-date and accurate.
We cannot cover all specific applications or anticipate all requirements.
All specifications are subject to change without notice.



Made in the U.S. A.

For more information, contact Notifier. Phone: (203) 484-7161, FAX: (203) 484-7118.
www.notifier.com