

FCM & FRM Series

Control and Relay Modules
with FlashScan®



Intelligent/Addressable Devices

General

FCM-1 Control Module: The FCM-1 Addressable Control Module provides Notifier intelligent control panels a circuit for Notification Appliances (horns, strobes, speakers, etc.) or to monitor a telephone circuit. Addressability allows the FCM-1 to be activated, either manually or through panel programming, on a select (zone or area of coverage) basis.

FRM-1 Relay Module: The FRM-1 Addressable Relay Module provides the system with a dry-contact output for activating a variety of auxiliary devices, such as fans, dampers, control equipment, etc. Addressability allows the dry contact to be activated, either manually or through panel programming, on a select basis.

FlashScan® (U.S. Patent 5,539,389) is a communication protocol developed by NOTIFIER Engineering that greatly enhances the speed of communication between analog intelligent devices. Intelligent devices communicate in a grouped fashion. If one of the devices within the group has new information, the panel CPU stops the group poll and concentrates on single points. The net effect is response speed greater than five times that of other designs.

Features

- Built-in type identification automatically identifies these devices to the control panel.
- Internal circuitry and relay powered directly by two-wire SLC loop. The FCM-1 module requires power (for horns, strobes, etc.), audio (for speakers), or a telephone riser (for handsets). Internal relay feature available on FlashScan systems only.
- Integral LED “blinks” green each time a communication is received from the control panel and turns on in steady red when activated.
- LED blink may be deselected globally (affects all devices).
- High noise immunity (EMF/RFI).
- The FCM-1 may be used to switch 24-volt NAC power, audio (up to 70.7 Vrms) or telephone.
- Wide viewing angle of LED.
- SEMS screws with clamping plates for wiring ease.
- Direct-dial entry of address 01– 159 for FlashScan, 01 – 99 on traditional systems.
- Speaker, audible/visual, and telephone applications may be wired for Class B or A (Style Y or Z).

Applications

The FCM-1 is used to switch 24 VDC audible/visual power, high-level audio (speakers), or control telephone devices. The FRM-1 may be programmed to operate dry contacts for door holders, Air Handling Unit shutdown, etc., and to reset four-wire smoke detector power.

Construction

- The face plate is made of off-white Noryl®.
- Controls include two rotary switches for direct-dial entry of address (01-159).

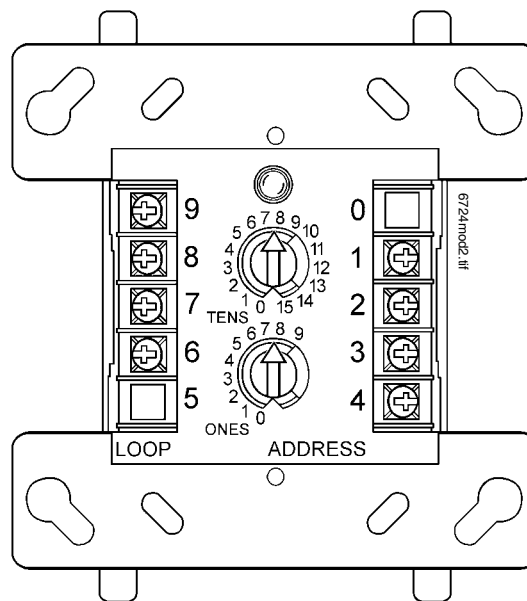

FCM-1 Module

(see wiring diagram Fig. 5 for FRM-1)

- The FCM-1 is configured for a single Class B (Style Y) or Class A (Style Z) Notification Appliance Circuit.
- The FRM-1 provides two Form-C dry contacts that switch together.

Operation

Each FCM-1 or FRM-1 uses one of 159 possible module addresses on a SLC loop. It responds to regular polls from the control panel and reports its type and status, including the open/normal/short status of its Notification Appliance Circuit (NAC). The LED blinks with each poll received. On command, it activates its internal relay. The FCM-1 supervises Class B (Style Y) or Class A (Style Z) notification or control circuits.

Upon code command from the panel, the FCM-1 will disconnect the supervision and connect the external power supply in the proper polarity across the load device. The disconnection of the supervision provides a positive indication to the panel that the control relay actually turned ON. The external power supply is always relay isolated from the communication loop so that a trouble condition on the external power supply will never interfere with the rest of the system.

Rotary switches set a unique address for each module. The address may be set before or after mounting. The built-in TYPE CODE (not settable) will identify the module to the control panel, so as to differentiate between a module and a sensor address.

Specifications for FCM-1

Normal operating voltage: 15 to 32 VDC.

Maximum current draw: 6.5 mA (LED on).

Average operating current: 350 μ A direct poll (CLIP mode), 375 μ A group poll (FlashScan® mode) with LED flashing.

External supply voltage (between Terminals T3 and T4): maximum 80 volts (RMS or DC).

Drain on external supply: 2 mA maximum (using internal EOL relay).

EOL resistance: 47K ohms.

Temperature range: 32°F to 120°F (0°C to 49°C).

Humidity range: 10% to 93% non-condensing.

Dimensions: 4.5" (114.3 mm) high x 4" (101.6 mm) wide x 1.25" (31.75 mm) deep. Mounts to a 4" (101.6 mm) square x 2.125" (53.975 mm) deep box.

Specifications for FRM-1

Normal operating voltage: 15 to 32 VDC.

Maximum current draw: 6.5 mA (LED on).

Average operating current: 230 µA direct poll (CLIP mode), 255 µA group poll (FlashScan® mode) with LED flashing.

EOL resistance: not used.

Temperature range: 32°F to 120°F (0°C to 49°C).

Humidity range: 10% to 93% non-condensing.

Dimensions: 4.5" (114.3 mm) high x 4" (101.6 mm) wide x 1.25" (31.75 mm) deep. Mounts to a 4" (101.6 mm) square x 2.125" (53.975 mm) deep box.

RELAY CONTACT RATINGS

FOR BOTH FCM-1 AND FRM-1 MODELS

Load Description	Application	Maximum Voltage	Current Rating
Resistive	Non-Coded	30 VDC	3.0 A
Resistive	Coded	30 VDC	2.0 A
Resistive	Non-Coded	110 VDC	0.9 A
Resistive	Non-Coded	125 VAC	0.9 A
Inductive (L/R=5ms)	Coded	30 VDC	0.5 A
Inductive (L/R=2ms)	Coded	30 VDC	1.0 A
Inductive (PF=0.35)	Non-Coded	125 VAC	0.5 A

Agency Listings and Approvals

In some cases, certain modules may not be listed by certain approval agencies, or listing may be in process. Consult factory for latest listing status.

- **UL:** S3705
- **ULC:** CS669
- **FM Approved**
- **CSFM:** 7300-0028:202
- **MEA:** 457-99-E
- **Maryland State Fire Marshal:** Permit # 2020

PRODUCT LINE INFORMATION

NOTE: "A" suffix indicates ULC Listed model.

FCM-1(A): Intelligent Addressable Control Module.

FRM-1(A): Intelligent Addressable Relay Module.

A2143-20: Capacitor, required for Class A (Style Z) operation of speakers.

SMB500: Optional Surface-Mount Backbox.

CB500: Control Module Barrier — required by UL for separating power-limited and non-power limited wiring in the same junction box as FCM-1.

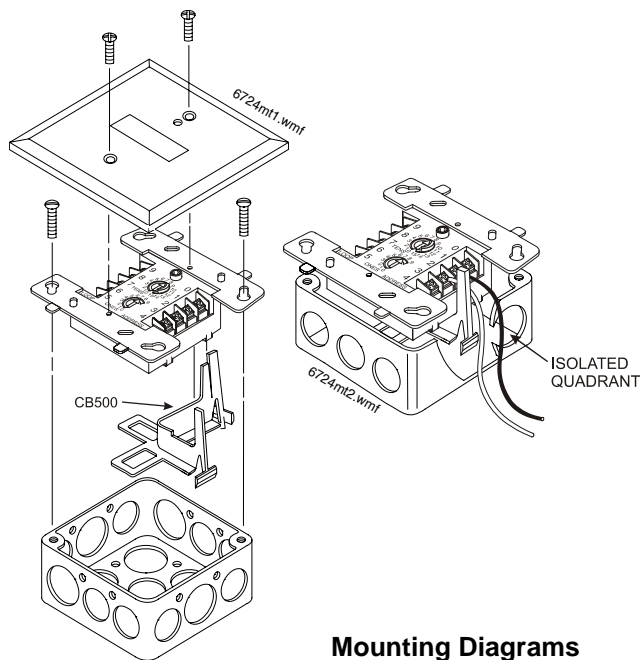

Mounting Diagrams
Note CB500 Module Barrier, which creates isolated quadrant.

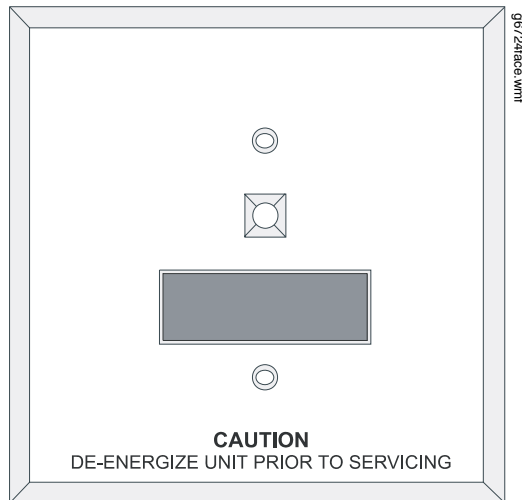

Figure 3 FCM-1

Typical wiring for speaker supervision and switching, NFPA Style Y.

- Connect modules to Listed compatible Notifier control panels only.
- All wiring shown is supervised and power limited.
- Wires must be supervised per NFPA.
- Module polarities are shown in alarm.

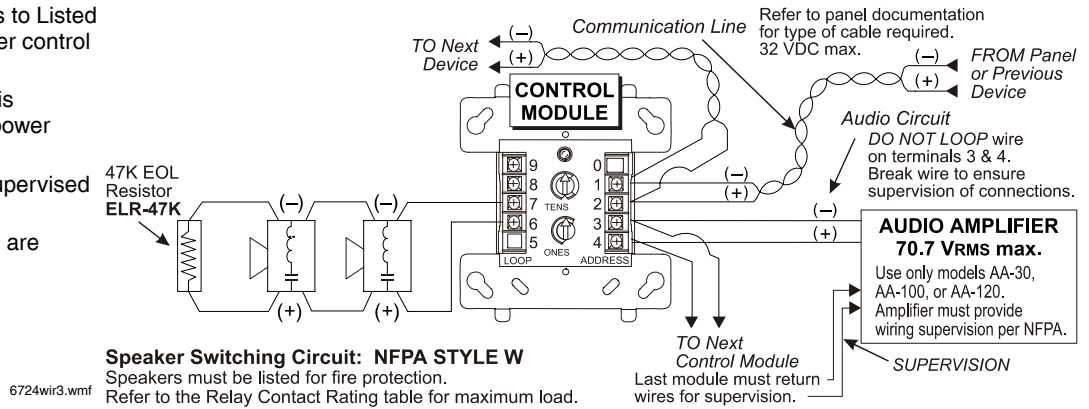
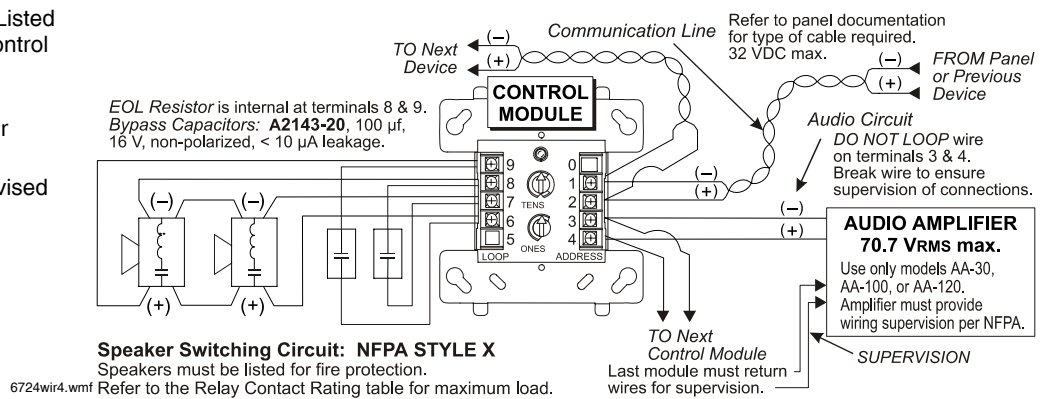

Figure 4 FCM-1

Typical fault-tolerant wiring for speaker supervision and switching, NFPA Style Z.

- Connect modules to Listed compatible Notifier control panels only.
- All wiring shown is supervised and power limited.
- Wires must be supervised per NFPA.
- Module polarities are shown in alarm.



NOTE: Regarding audio amplifier in Figures 3 and 4 above. Audio circuit wiring must be twisted-pair as a minimum. See Notifier installation manual for detailed information.

Figure 5 FRM-1

Relay module wiring diagram.

- Connect modules to Listed compatible Notifier control panels only.
- Module does NOT supervise controlled circuits.

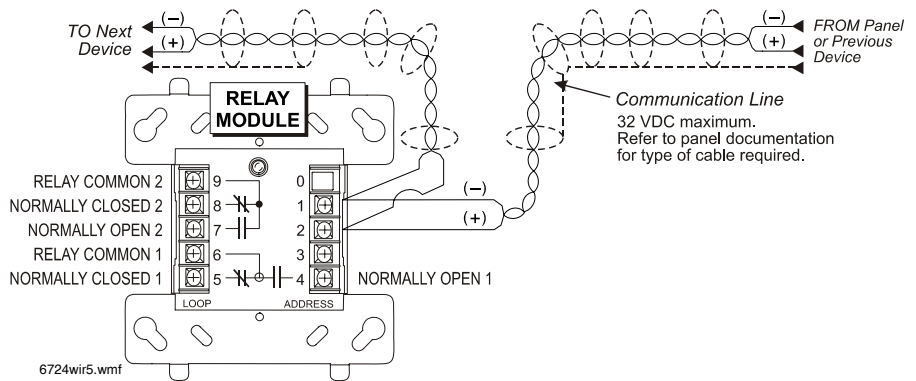

Notifier® and FlashScan® are registered trademarks of Honeywell International Inc. Noryl® is a registered trademark of GE Plastics, a subsidiary of General Electric Company.
©2007 by Honeywell International Inc. All rights reserved. Unauthorized use of this document is strictly prohibited.



This document is not intended to be used for installation purposes. We try to keep our product information up-to-date and accurate. We cannot cover all specific applications or anticipate all requirements. All specifications are subject to change without notice.



For more information, contact Notifier. Phone: (203) 484-7161, FAX: (203) 484-7118. www.notifier.com