

# The Specification

## SL20/25/30GA/SL30GB SLG Series Of Electric Pallet Truck

**Note:** Before using, please read this manual !

Before the installation is complete, please do not use.

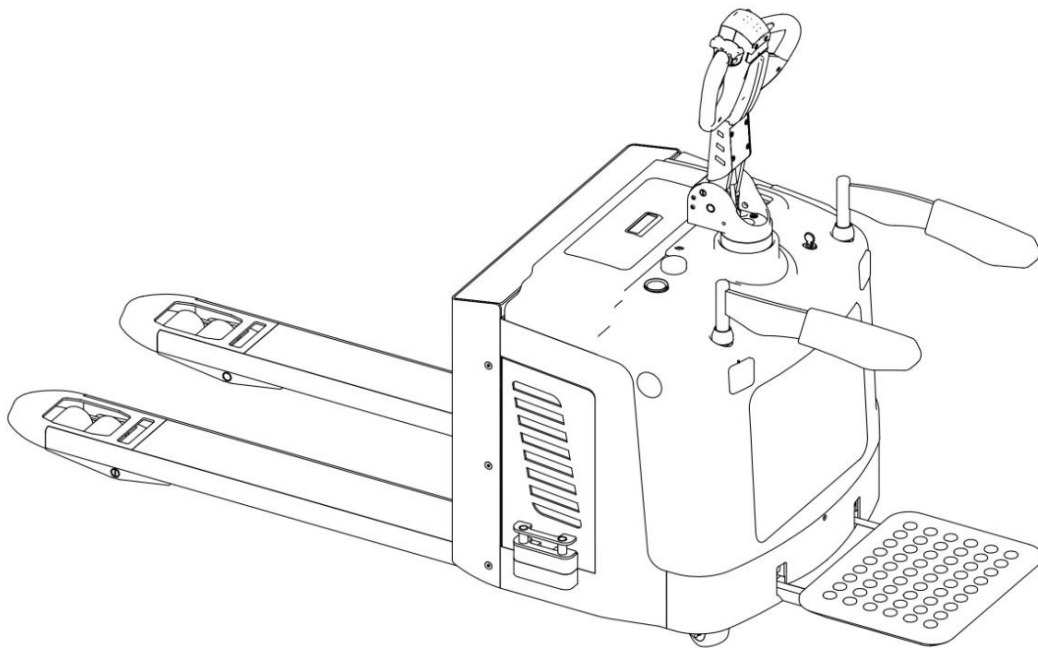

# Contents

一、 The Introduction Of Motorcycle Type.....	1
1.1 Model overview.....	1
1.2 Model parameters.....	1
二、 Basic structure and principle.....	3
2.1 Basic structure.....	3
2.2 Operating principle.....	4
三、 Safety operation and matters needing attention.....	11
3.1 General rule.....	11
3.2 Storage and transportation.....	11
3.3 Check before using.....	12
3.4 Operation specification.....	12
3.5 Safe Operation Rules.....	17
四、 Maintenance and Service Manual.....	21
4.1 Repair and maintenance of safety procedures.....	21
4.2 Routine Maintenance (Before every shift).....	22
4.3 Professional Maintenance Manual.....	23
4.4 Maintenance, Recharging and Replacement of the accumulator.....	25
五、 Repair Manual.....	31
5.1 Fault Diagnosis.....	31
5.2 Preparation before repair.....	32
5.3 Check hydraulic oil level.....	32
5.4 Use Preparation after maintenance or repairing.....	32

# 一、 The Introduction Of Motorcycle Type

## 1.1 Model overview

This manual collects SLG series, 2.0 to 3.0 metric tons of all electric pallet truck ( Hereinafter referred to as "truck" ) 。

The truck models “SL20GA—20 rated load 2.0 tons、SL25GA—25 rated load 2.5 tons、SL30GA—30 rated load 3.0 tons、SL30GB—30 rated load 3.0 tons” meet the requirement of JB/T8452-1996 《Battery forklift model establishment method》，“G” is the product code, “A/B” is model code。

## 1.2 Model parameters

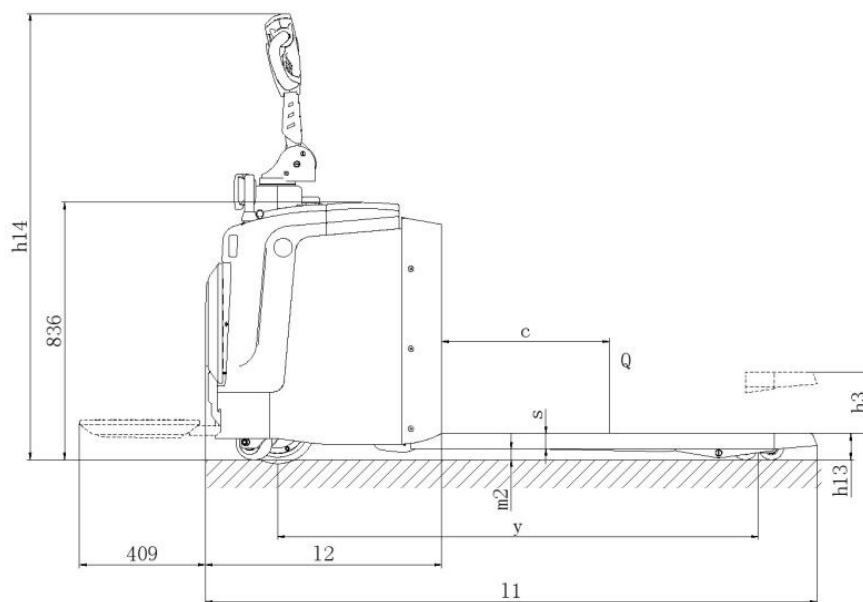

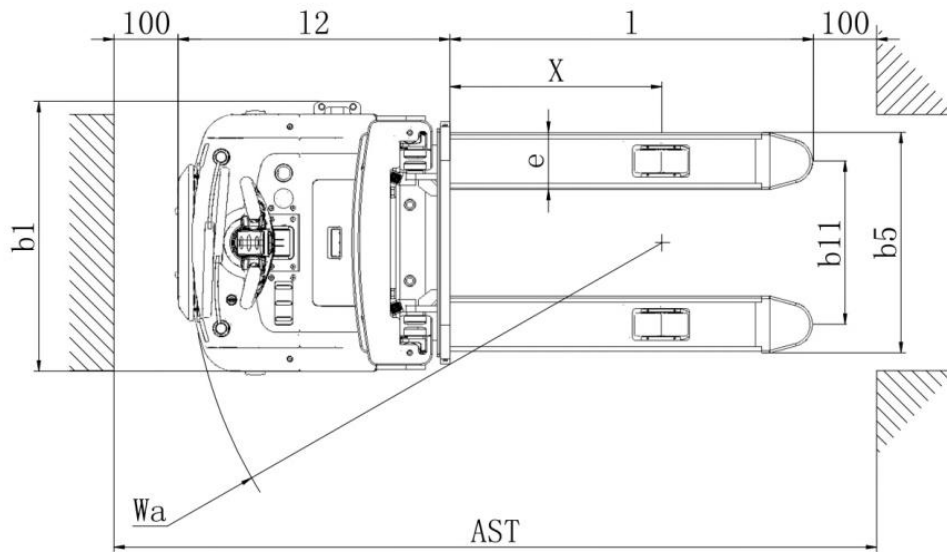

Model		SL20GA	SL25GA	SL30GA	SL30GB
Load capacity	Q(kg)	2000	2500	3000	3000
Fork length	l(mm)	1150/1220	1150/1220	1150/1220	1150/1220
Overall fork width	b5(mm)	540/685	540/685	540/685	540/685
Single fork width	e(mm)	185	185	185	185
Lowered fork height	h13(mm)	85	85	85	85
Lifting fork height	h3(mm)	115	115	115	115
Overall length(with Pedal unfolded )	l1(mm)	1925 ( 2320 )	1925 ( 2320 )	1925 ( 2320 )	1977(2377)
Overall width	b1(mm)	888	888	888	805
Overall height	h14(mm)	1450	1450	1450	1460
Wheel size, front, number		φ 80×80、4	φ 80×80、4	φ 80×80、4	φ 80×80、4
Wheel size,driving, number		φ 250×75、1	φ 250×75、1	φ 250×75、1	φ 250×75、1
Balance wheel, number		φ 115×55、2	φ 115×55、2	φ 115×55、2	φ 115×55、2
Turning radius	W ( mm )	1760	1760	1760	1720
Load center distance	c ( mm )	600	600	600	600
Lifting Motor		24V/0.8kw	24V/1.2kw	24V/1.2kw	24V/1.2kw
Driving Motor		24V/1.5kw	24V/2.0kw	24V/2.5kw	24V/2.5kw
Steering Motor		24V/0.2kw	24V/0.2kw	24V/0.2kw	24V/0.2kw
Battery voltage		210Ah/24V	210Ah/24V	210Ah/24V	240Ah/24V
Working time of fully charged batteries	(h)	6	5	5	5
Service Weight(without battery)	(kg)	810 ( 600 )	830 ( 620 )	850 ( 640 )	820(580)

## 二、 Basic structure and principle

### 2.1 Basic structure

With battery as power producer and controlled by electrical and hydraulic, trucks can do some actions like walking, turning, pallet fork lift, ect.

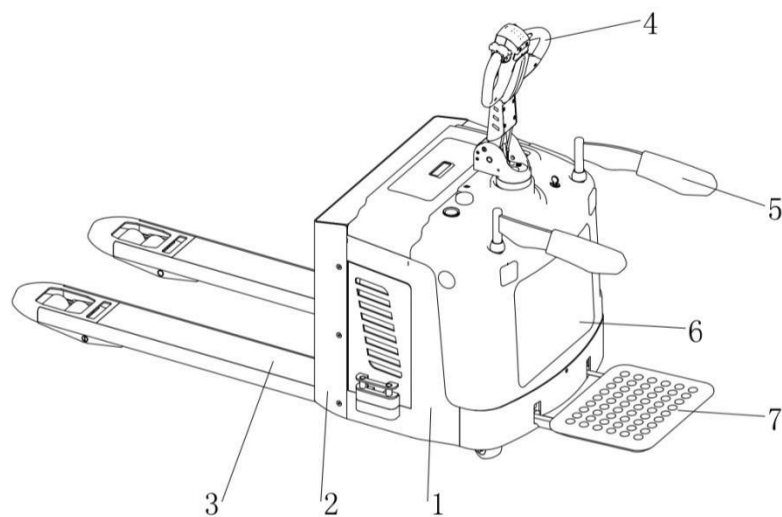

- |                              |                 |                        |          |
|------------------------------|-----------------|------------------------|----------|
| 1. distribution box assembly | 2. front shield | 3. fork frame assembly |          |
| 4. hand shank                | 5. hood         | 6. barcer              | 7. pedal |

## 2.2 Operating principle

### 2.2.1 Running system

It is battery provides energy storage and the frequency conversion system converts direct current to alternating current that make the truck walk. Ac motor transforms high speed low torque into low speed high torque through the gear reducer, and finally by the driving wheel to perform actions. Walking speed is achieved by variable frequency control of motor speed and controlled by the accelerator.

Gear box in the factory has been posited enough gear lubricating oil. And please change the gear lubricating oil every 1000 hours under normal circumstances.

If you hear abnormal sound from gear box when using, please stop and check immediately. If there are bearing failure or some problem in gear, please replace and repair them.

### 2.2.2 Steering system

The operating handle drives the rotation direction sensor which can send out the turn signals that makes the truck turn around.

### 2.2.3 Operating system

1. Hoisting and falling button
2. Driving switch
3. Belly switch
4. Horn button

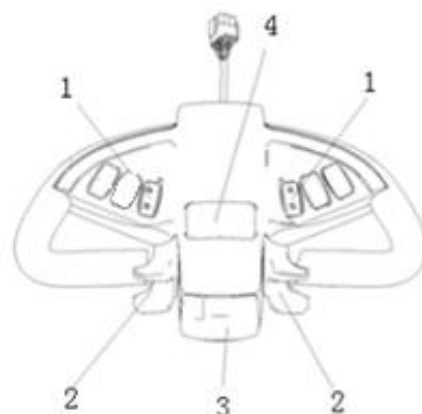

## 2.2.4 Braking system

Braking performance depends on road conditions and vehicle load conditions.

The brake function can be activated by the following ways:

- Turn the travel switch (2) to "0" position or release the switch to make truck brake until it stops.
- Move driving switch (2) directly from a driving directions to the opposite direction, truck regenerative braking until it began in the opposite direction.
- Move the handle up and down to the braking area ( 'B' ), truck braking. If the handle is released, it will automatically move to the braking area (" B ") ,and the truck brakes until it stops.
- Belly switch (3) is set for preventing the operator squeezed. When the truck is driven towards ( ' Fw ) and encounters an obstacle, and driver's body touches belly switch ,the truck will slow down or drive to ( ' Bw' ) for a distance and then stop. If the handle is in operation area but the truck is not driving, please consider if it still work.

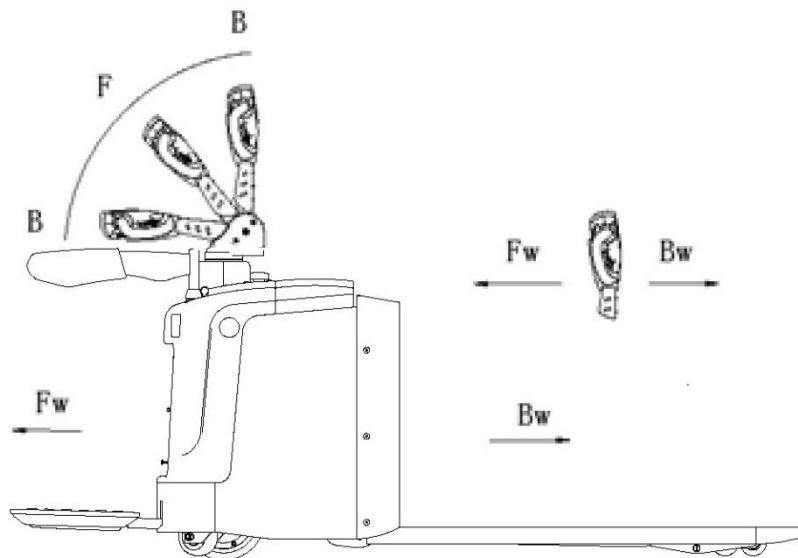

### **2.2.5 Operating System**

The truck's main work part are pallet forks which are used to carry tray or goods.

The operating handle controls stretch of oil cylinder, and the pump station provides pressure oil.

There is a lowering speed control valve set in the loop of lifting oil cylinder to make the fork landing speed reach to safety level.

## **2.3 Electrical principle**

### **2.3.1 Electric System**

Truck electrical system includes walking and job control, etc. Truck uses American CURTIS1232E electronic assembly.

Instruments can display electric power, working time and have low voltage protection function. When the battery power is too low, electricity meter will cut off the oil pump motor start control circuit, and truck can only walk and cannot lift forks, and at that time it will remind you to charge immediately.

The oil pump motor is a continuous current dynamo with 5 minutes working system, so it is not suitable for continuous operation for a long time. There should be some time intervals between lifting actions, otherwise it will make motor fever, even destroyed.

Special tips: When the truck are used for a long time, the oil pump motor starter likely to fail, embodied in can't absorb close or close after



disconnection. After being used for a long time, the oil pump motor starter may arise some problems which perform as not combining or not breaking. If the control handle is not pulled, the oil pump motor is kept in the rotation. At that time, please stop and cut off power supply and replace the starter in time.

# Electrical schematic diagram

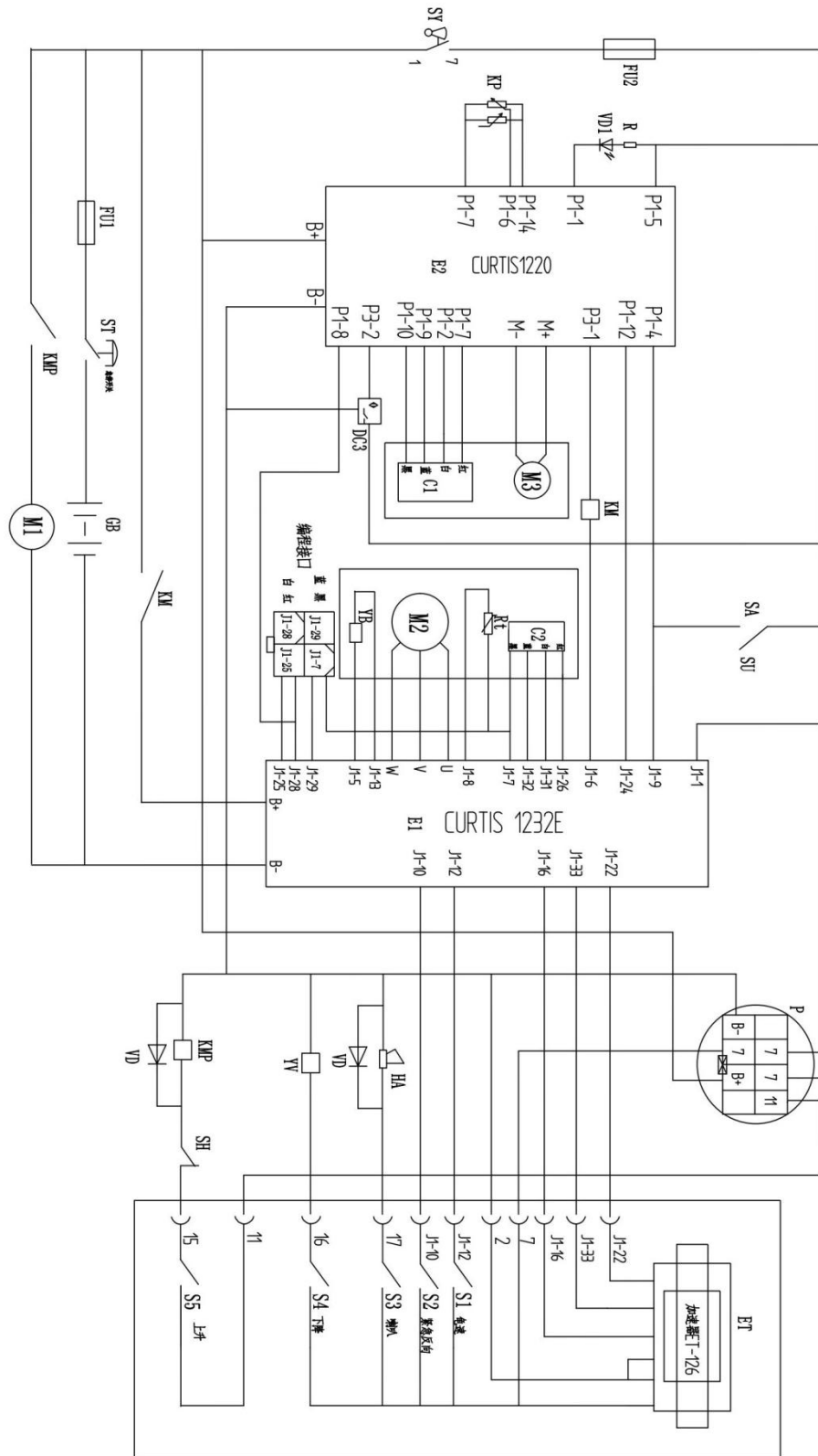

SLG series charged electrical schematic diagram



## 2.4 Hydraulic principle

The oil pump motor driving gear pump, it provide hydraulic power, two lifting cylinder are responsible for lifting the fork. Lifting oil way is controlled by handle. Lifting action is controlled by single-acting oil way which on the valve block. This model of the hydraulic system pressure are tested before they go out, not my company after-sales personnel or professional maintenance personnel are strictly forbidden to adjust themselves, so as to avoid safety accident.

### Hydraulic scheme

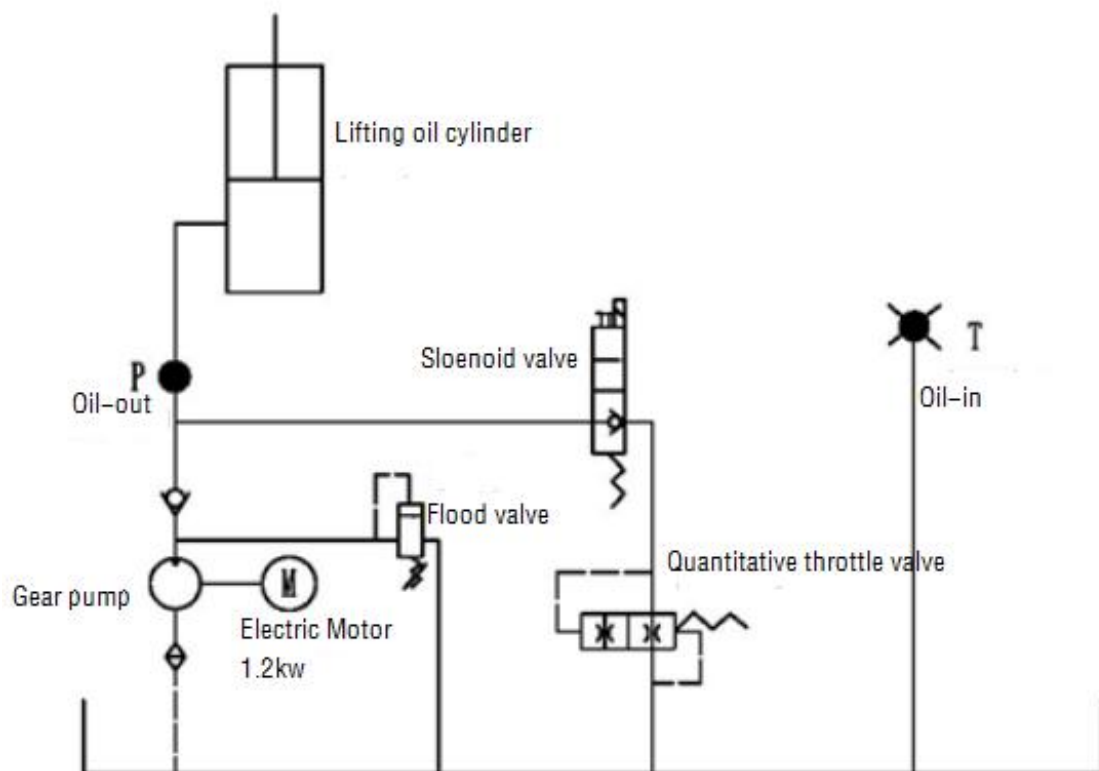

## **三、Safety operation and matters needing attention**

### **3.1 General rule**

**3.1.1** The operator must have a forklift operation qualification which proved by the relevant departments of the training before driving forklift truck.

**3.1.2** The operator must read the instructions before use all of the content, after fully understand operation method can drive forklift.

**3.1.3** Forklift trucks must not carry passengers.

**3.1.4** Operators should pay special attention to when homework operating environment, including other people nearby and fixed object.

**3.1.5** Without the manufacturer's approval, shall not modify, add or remove the forklift parts, lest affect performance of forklift.

### **3.2 Storage and transportation**

**3.2.1** Use container or car should pay attention to at the time of shipment:

① Front and rear wheels with wedge, begin to pull up the parking system, prevent sliding in the process of transportation;

② Using the lasso, not placed in the weak structure of the forklift truck;

③ When the forklift is used, keep the forklift truck's center of gravity in the intermediate position of the two goods forks.

**3.2.2** When forklift doesn't work, should be parked in a dry ventilated cleaning warehouse, prevent weathered. And:

- ① Close electric lock, make the safety switch power, unplug the power plug;
- ② Begin to pull up the parking system, front and rear wheels with block mat;
- ③ Such as discontinued for a long time, battery should be added once every 15 day electricity.

### **3.3 Check before using**

**3.3.1** New car if there is any damage in transit, please don't be put into use, and promptly get in touch with the supplier, do proper processing.

**3.3.2** New cars in the factory run parts has been filling lubricating oil, hydraulic oil tank has been listed.

**3.3.3** Forklift truck equipped with battery. The battery is charged before leaving factory. If leaving the factory for a long time, may the battery is low. Before use should pay attention to electricity meter shows that when the electricity meter display to the last two warning, must charge at once. Every day before using, or before charging, should open the battery blocks, check the liquid level height, such as liquid level is too low to add distilled water in charge.

### **3.4 Operation specification**

Before operating the forklift, please be familiar with the dashboard function of each switch/button.

### 3.4.1 Start, run and parking:

- ① Insert the key into the key switch, turn to the right, the emergency power safety switch clockwise reset, gently open the control circuit.
- ② The fork rises from the ground about 10 cm.
- ③ Begin to loosen parking system.
- ④ According to the requirements in the direction of the forward or backward direction of switches.
- ⑤ On the accelerating pedal slowly, until the required speed.
- ⑥ In the process of operation, forklift exception occurs fault, need to quickly cut off power supply, please press the red emergency power switch.
- ⑦ When forklift driving turn, should reduce speed, where possible, try not to turn.
- ⑧ Forklift truck carrying gradability is 10%, so the uphill slope need to understand the situation, when climbing the forklift must accelerator pedal pressed down as far as possible, the maximum climbing force can be achieved.
- ⑨ Forklift in the process of downhill, loosen the accelerator pedal, in order to obtain the reverse braking current, if the reverse current can't control the downhill braking speed. Please on the brake pedal at the same time, to ensure safety.
- ⑩ When stopping driving, leave the accelerator pedal, right foot on the pedal until the forklift stop completely. Put the pallet fork in the lowest

position, taut hands in the car, press the safety switch, pull out the key.(Note that can't leave without a taut hand brake lever forklift).

### **3.4.2 The steering wheel Angle adjustment**

According to the individual operating habits, steering wheel angle can be adjusted . Adjustment method is as follows:Loosen the left hand of direction column,adjust the steering wheel to the right position, then lock regulating handle.

### **3.4.3 Accelerator pedal operation**

Determine the vehicle forward or backward. Toggle joystick in place, right foot will tread the foot pedal accelerator to make the vehicle slowly forward or backward. Continue down the pedal, the vehicle's speed to speed up. Started never put foot accelerator jammed on to the end, in order to avoid the vehicle out of control.

### **3.4.4 Brake pedal operation**

When the vehicles need parking in moving , loosening the foot accelerator, Will move to the right foot on the brake pedal in the middle to depress and the vehicle will stop after .

### **3.4.5The using of emergency power safety switch**

When vehicles out of control on the moving, or having smoking and anxious burnt flavour in the using, please pressed emergency switch on the dashboard shut off.Find out the reason and clear fault than to open. The method of the



opening:turn the red button as clockwise,pop-up button up, open end.

Emergency power switch button for plastic parts, press down or clockwise not too hard, so as not to damage the switch.

#### **3.4.6 The use of speakers and reversing speakers**

For the safety of driving, vehicle equipped with speakers and reversing speakers. To remind others when driving, the steering wheel in the middle of the horn button, when walking vehicle reversing, reversing the horn alarm sound will start automatically alert pedestrians.

#### **3.4.7 The operation of the hydraulic control rod**

Hydraulic control rod is for hydraulic transmission parts distributor of different needs, there are two files, joystick is divided into the following functions:

(1) Pallet fork lift lever: a. fork to ascend (after); b.fork remain ; c.fork lower (push)

(2) Tilt lever: a. hypsokinesis (after); B. stay in situ; C. forward (push)

Every joystick can only manipulate a hydraulic circuit. Joystick when dial, with micro switch will start the oil pump motor rotating at the same time, the output pressure of hydraulic oil, make the related hydraulic components. In order to ensure the safety of hydraulic system pressure, the hydraulic valve block is equipped with pressure relief devices, once set pressure exceeds standard, control valve block automatically unloading overflow.

Note: the pressure of the hydraulic valve block device, can not adjust at will!

#### **3.4.8 Battery capacity indicator**

The dashboard for forklift battery capacity has capacity display function, can also use electricity time statistics (cumulative hour).

### **3.4.9 Handling stacking operation**

#### **(一) How to transport the goods pile on weight**

Will forklift drive to the front of the items which need to carry slowly , make fork parallel to the ground, lifting the fork to height, it can be inserted into the freight insert goods fork and move forward slowly, when the goods completely inserted into the goods after parking and stepping on the brakes, manipulating ascend handle, the heavy lifting to a certain height, make the door frame lean back, slowly astern, don't touch the adjacent goods, when weight completely left the heap of goods, reduce the goods to the right position, then walking for handling.

#### **(二) The weight on the heap of goods**

Will weight low, lean back door frame, to storage goods moving close to the pile of deceleration, when determining forklift with pile goods into a linear state, stepping on the brakes slowly adjust the door frame Angle to the vertical state, increase the weight will be slightly more than goods pile height, and then slowly driving forklift driving forward to pile top stop. Heap controls control lever slowly, once handling stacked drags the weight, the goods fork to the hollow position, from the weight of the goods fork, make sure barrier-free backward position, can retreat. After goods fork out weight reduce goods fork, door frame round of the reentry after handling operation.

## 3.5 Safe Operation Rules

**3.5.1 Requirements for drivers:** The forklift must be operated by a trained staff. He can demonstrate the operation of the goods to the users, and can clearly guide the user how to operate the forklift.

**3.5.2 Drivers' rights, obligations and responsibilities:** Has been trained by the operation of the vehicle, the driver must be clear of his rights and obligations; and he is familiar with the contents of the relevant operating instructions. If the vehicle is pedestrian, the driver must also wear safety boots.

**3.5.3 Prohibit unauthorized personnel to operate:** the driver is responsible for the vehicle at work. He must prevent unauthorized persons from driving or operating this vehicle. It is forbidden to use the vehicle to transport or lift personnel.

**3.5.4 Malfunctions and defects:** There is any malfunction or defect for the vehicle, must immediately inform management. If the vehicle cannot be safely operated (e.g.: wheel wear or brake failure), then it must stop using until it is fully repaired.

**3.5.5 Safe operation and environmental protection:** inspection and maintenance must be performed in accordance with the time intervals on the maintenance list.

Parts of the vehicle cannot be changed without any permission, especially safety devices. The operating speed of the vehicle is not allowed to change.

All original spare parts have been verified by quality assurance

department. To ensure the safety and reliability of the operation of the vehicle must use only the manufacturer's spare parts. The old parts, such as oils and fuels must be handled in accordance with the relevant environmental protection rules.

**3.5.6 Hazardous area:** Hazardous area usually refers to the following range: vehicle or its load lifting devices (e.g. fork or accessories) is dangerous for personnel when running or lifting movements, or the ongoing regional transport loads. Typically, this range extends to the load or vehicle accessories landing area.

Unauthorized personnel must be asked to leave the dangerous zone. As long as the situation might cause some kind of damage, the driver must give a warning, if the driver asked the person to leave but did not leave the danger zone, the driver must immediately stop the vehicle

**3.5.7 Risk environment:** When working in high-risk environment, you must have a special design to be protected

The vehicle was not specially designed for the high-risk environment.

**3.5.8 Safety devices and warning signs:** Safety devices, warning signs and warning notes described in the previous operating instructions must be taken seriously enough.

**3.5.9 Driving in public places:** the vehicle is forbidden to drive in public places other than special areas.

**3.5.10 distance between vehicles:** Keep in mind that the vehicle in front could

suddenly stop at any time, so please keep an appropriate distance.

**3.5.11 headroom:** When the headroom is below the cargo or mast, it is prohibit using the vehicle.

**3.5.12 the use in the elevator and loading platform maneuvering:** if there is sufficient loading capacity, does not affect the operation of the vehicle, and agreed by the user of the vehicle, lift and loading platform that can be used for vehicle transport. Before entering the elevator or loading station, driver must personally identify. The goods must be placed in front and occupy an appropriate place, when the vehicle enters the elevator, so as not to contact with the walls of the elevator. When personnel and vehicles take the elevator together, personnel must enter after the vehicle safety entered, and personnel must leave before the vehicle.

**3.5.13 with access and working area:** The vehicle must be operated on the specified channel, all the non-related personnel must leave the work area, and cargo should be stacked in designated places.

**3.5.14 Operations Management:** traveling speed must be adapted to local conditions. When through the corners, narrow passage, swing doors and closed place, the vehicle must slow down. Drivers must be able to visually an adequate braking distance between the vehicle and the vehicle in front, and he must remain in control of his vehicle. Sudden stop (unless urgent needs), rapid U-turn, chased each other in the channel is not allowed in not smooth places. It is forbidden to operate while the body is lean outside.

**3.5.15 Visibility:** The driver must look in the direction of travel, to ensure that the front situation is clearly visible. When the vehicle is backing up with the carriage of goods blocked the line of sight, there is must be a second person walk in front of the vehicle to give appropriate guidance and warnings.

**3.5.16 via the ramp:** Only known ramp was allowed to go through. While the ramp should be clean, non-slip, and the vehicle technical specification includes the ramp. The goods on the forks must face uphill. It is forbidden to turn back, move diagonally or park on the ramp. The driver must slow down when going through the ramp, and prepare to brake at any time.

**3.5.17 ground load:** Remember to check the load pressure of the body weight or wheels on the ground does not exceed the capacity of the ground, when the vehicle is in operation.

**3.5.18 Vehicle Change:** any possible changes or modifications for rated load, stability or safe operation of the vehicle, must obtain prior written approval from origin manufacturers or its successor. After vehicle manufacturer check and approve the changes, nameplates, labels and markings of Operation and Maintenance Manual must be modified as well.

## 四、 Maintenance and Service Manual

### 4.1 Repair and maintenance of safety procedures

**Maintenance technician:** The maintenance and service should only be performed by special personnel trained by the manufacturer. After the technician sent by after-sales department of the manufacturer completed maintenance and servicing work, they should sign on the service log.

**Cleaning Operation:** Flammable liquid can not be used for cleaning the stacker. Before cleaning, take safety precautions to prevent electric sparks (e.g. sparks caused by short circuit). When operating the accumulator, connectors on it must be disconnected. Use soft air suction or compressed air, non-conductive and anti-static brushes to clean electric and electronic components.

**Operation of Electric System:** Operation on the electric system should only be performed by specially trained personnel. Before performing any operation on the electric system, precautions must be made to prevent electric shock. When operating the accumulator, connectors on it must be disconnected.

**Installation:** When repairing or replacing hydraulic components, electric and electronic components, make sure to install them back to their original positions.

**Wheels:** Quality of the wheels has significant effect on stability and driving performance of the stacker. Modification on wheels can be performed only

with the approval from the manufacturer. When replacing wheels, ensure that the stacker is levelled as delivery state(wheels must be replaced in pairs, i.e. replace right wheel together with left one).

**Lifting chain and rollers:** Chain and rollers will be worn quickly without good lubrication. Perform periodic lubrication according to following maintenance table. Shorten the lubrication period under adverse operation conditions (such as in dusty and hot environment).

**Hydraulic oil pipe:** The oil pipe must be changed every 6 years. When change the hydraulic assembled parts, the oil pipe should be also changed.

#### **4.2 Routine Maintenance (Before every shift)**

**4.2.1** Check the liquid level of electrolyte in the accumulator.

The liquid level will be higher when being recharged.

**4.2.2** Check every pole, every cable and their covers.

**4.2.3** Check if the accumulator box is secured.

**4.2.4** Check the stacker for oil leakage.

**4.2.5** Check the chain, rollers, fork, oil pipes and horn.

**4.2.6** Check the brake.

**4.2.7** Check the wear and tear of drive wheels and loading wheels.



## 4.3 Professional Maintenance Manual

It is very important for safe operation of the stacker to perform overall professional maintenance. Failure in performing maintenance according to specified interval may cause malfunction of the stacker, and potential risk to human and equipment.

Maintenance periods listed in this manual apply to single shift a day under normal operation conditions. If using in dusty environment, the ambient temperature varies remarkably or in multi-shift situation, the maintenance period has to be shortened.

Maintain the stacker according to following maintenance list. Maintenance periods are as follows:

W1 = Every 50 work hours, but at least once a week.

M3 = Every 500 work hours, but at least once every three months

M6 = Every 1000 work hours, but at least once every six months

M12 = Every 2000 work hours, but at least once every 12 months

Additional operations should be performed in trial run period:

(In initial 50 – 100 working hours or after two months)

— Check the nuts on the wheels, and tighten them if necessary.

— Check the hydraulic components for leakage, and tighten them if necessary.

— Replace the hydraulic filter.

## List of maintenance

			4.2 Time interval of maintenance			
			W	A	B	C
Braking	1.1	Check the air gap of electromagnetic brake			●	
Electric System	2.1	Check switch operation, display the function of the equipment and components	●			
	2.2	Check the alarm system and safety device		●		
	2.3	Check whether there is any damage on the cable and terminal is rigid			●	
	2.4	Check the function of the micro switch Settings	●			
	2.5	Check the controller and EPS controller			●	
	2.6	Fixed cable and motor			●	
Energy Supply	3.1	By observing the battery		●		
	3.2	Visual inspection battery charging plugs			●	
	3.3	Check whether the battery cable connection fastening, if necessary, with oil daub electrode			●	
Traveling System	4.1	Check if have gearbox abnormal sound			●	
	4.2	Check the travel agency, and the oil, check the reset function of operating handles		●		
	4.3	Check the drive wheels and bearing wheel for wear and damage			●	
	4.4	Check the wheel bearing and fixed			●	
Massive Structure	5.1	Check whether the framework has damaged			●	
	5.2	Check whether the sign is complete			●	
	5.3	Check the door frame fixed situation			●	
The hydraulic system	6.1	Check the function of the hydraulic system		●		
	6.2	Check the hoses, pipes and interface whether fastening, sealing and		●		
	6.3	Check whether the damaged piston and cylinder, sealed and fixed			●	
	6.4	Check the load chain Settings,			●	
	6.5	Visual inspection door frame and check on the surface of the roller of roller wear			●	
	6.6	Check the goods fork teeth and load parts for wear and damage			●	
	6.7	Check the tank oil level			●	
	6.8	Update the hydraulic oil				●

## **4.4 Maintenance, Recharging and Replacement of the accumulator**

The stacker must be parked in a safe location before any operation on the accumulator.

### **4.4.1 Maintenance Technician**

Only qualified technician can perform operations on the accumulator such as recharging, maintenance and replacing. Before operation carefully read instruction manuals including operation manual, replenishment preparation and recharging requirements.

### **4.4.2 Fire Prevention Measures**

Never smoke or use open fire when perform operations on the accumulator. The accumulator should be away from flammable material at least two meters when storage or recharging. The location for accumulator storage should be well ventilated and equipped with fire fighting devices.

### **4.4.3 Maintenance of the Accumulator**

- 1) Keep the nuts on every battery cell dry and clean. Tighten every terminal and cable end, and brush them with grease to prevent corrosion. Naked cable ends and terminal posts should be covered with a skid-proof insulating cover.
- 2) Every two cells should be well-connected. Check the nuts on each pole, if loose, tighten the nuts.

- 3) Keep the surfaces of accumulator clean and dry. After the completion of recharging, clean spilled acid with cotton yarns or brush. And clean with wet towel if necessary.
- 4) Over recharging and over discharging should be avoided, and fast charging and insufficient recharging are also not allowed. Otherwise life span of the accumulator may be affected.
- 5) Do not put conductive objects including metal tools on the accumulator, or short circuit or even explosion may be caused.
- 6) Never spill any hazardous liquid or solid material on surfaces of the accumulator. When using a densimeter or a thermometer, make sure the surface is clean and clear.
- 7) Recharge the discharged accumulator in time. Delayed recharging may damage the accumulator. Do not delay recharging more than 24 hours. Recharging of the accumulator may not work outdoors in cold weather. In this case, move it indoors to perform recharging.
- 8) If the accumulator will not be in use for a long time, it should be recharged and discharged once every month and it should be fully recharged every time.
- 9) During recharging or using, the liquid level of electrolyte lowers because of water evaporation, so pure water should be added. It is not allowed to add electrolyte with a specific weight of 1.280.

10) If individual cell fails, identify the cause and repair the cell immediately.

Replace the cell when it cannot be repaired.

11) The site for recharging should be well ventilated. It is prohibited to smoke or use open fire, avoiding the risk of hydrogen explosion.

12) The electrolyte in accumulator is toxic and corrosive. For this reason, always wear working suit and protection glasses to protect your body from contacting the electrolyte in accumulator.

13) If your clothes, skin or eyes are spilled with acid liquid in accumulator, flush with large amount of clean water. For skin and eyes, flush with large amount of clean water and also seek doctor's treatment immediately. Acid spillage must be neutralized and treated immediately.

14) The weight and dimensions of the accumulator have remarkable effect on stability of the stacker. Therefore do not modify the type of accumulator without approval from the manufacturer.

15) Never discharge in large current, for example, performs travelling and lifting simultaneously.

#### **4.4.4 Disposition of worn-out accumulators**

Worn-out accumulators should be recycled according to local regulations, and stored in specified zone or cast-off treatment zone. These works should be done by qualified specialized companies.

#### 4.4.5 Specification of the accumulator

Battery		Charger	
Rated power: 24V	Rated capacity: 210/240Ah	Input: 195/265VAC 50/60Hz	Output: DC24V30A

Uninsulated terminal poles on the accumulator should be protected with an insulated cover. When connecting the accumulator and socket, make sure to stop the stacker and put the switch at position “0”.When replace or install the accumulator, make sure the accumulator is fixed securely in battery box.

#### 4.4.6 Storage, transportation and installation of the accumulator

The stacker must be parked on the level ground steadily. To prevent short circuit,naked cable ends and the terminal posts should be covered with insulated covers. When pulling out the accumulator, properly arrange removed accumulator's connectors and cables without blocking access of the accumulator.

When install or remove the accumulator with a crane, make sure the load capacity is sufficient (weight of the accumulator is marked on both the nameplates of the accumulator and the stacker.) The crane must pull vertically to prevent the battery box from being damaged. The hooks of the crane should be safe and secure. Never let the hooks fall on an individual battery .

— Press emergency stop switch and turn the power supply switch to

## OFF position

— Remove the connectors of accumulator cables.

—Connect the lifting device to lifting holes.

—Lift out the accumulator from the top and move away with handling equipment.

Perform installation in reverse order of above steps. It is noticeable to put the accumulator in right position and connect the cables securely. After reinstalling the accumulator, always check all cable connections and connectors for obvious damage.

### 4.4.7 Battery power indicator

Battery power display table:ten article showing represent 100% of the battery.

With the consumption of battery capacity, the glowing article shows will be from top to down.

The color of LED show the different states :

Name	LED Color	
The standard battery remaining power	Green	70-100%
	Orange	30-60%
	Red blinking	0-20%

Battery discharge on 70%, red lamp will blinking “Energy storage” ;

Battery discharge on 80%,two lamp will blinking “run out of battery” ,Must to the accumulator.



Full



Need to recharge



Low battery

#### **4.4.8 Charging**

The Electric stackers is supplied with a special charger for recharging.

**A:**Read the instruction manual carefully before recharging.

**B:**The batteries should be recharged in well-ventilated areas. Make sure no metal objects placed on the accumulator. Check all cables connection and connectors for obvious defects. Observe strictly all safety instructions, e.g. replenishment of the accumulator and preparation for recharging.

**C:**Hydrogen will be precipitated in the charging process. So the accumulator room should be well-ventilated, and the hydrogen content shall be strictly controlled to ensure safety.

**D:**For the safety of the cooperation, the stacker should be added protective cover before using.



# 五、Repair Manual

## 5.1 Fault Diagnosis

fault	cause	Processing method
The vehicle can't move	The battery connector is not connected	Check the battery connector , connected if necessary
	Electric lock switch on “0”	Electric lock switch turn right
	Emergency Stop Switch not open	Open the Emergency stop switch
	Battery power runs out	Check the battery charge , If it is necessary to recharge
	The stacker being charge	Interrupt charging process
	The fuse is damaged	Check the fuse
The goods cannot ascend	The stacker no running	According to the "vehicle can not move" listed in the fault processing method of operation
	Less hydraulic oil	Check the hydraulic oil
	The fuse is damaged	Check the fuse
	Over weight	Note the load capacity
The goods can't drop	the micro switch of lifting contact is not good or damaged	Check the fuse
	The dirty oil blocking control valve	Check the hydraulic oil and cleaning control valve, and if necessary change, the hydraulic oil.
Can't stop rising	Lowering solenoid valve no open or damaged	Check the lowering solenoid valve or change
	Lifting micro switch damaged	Cut the power, change lifting micro switch
A direction moving	Micro switch and cable jumper contact is not good	Check the micro switch and connect jumper witch on the control handle
The stacker move slowing	Battery power shortage or homologous cable jumper contact is not good	Check the battery power led and homologous cable jumper contact.
The car suddenly started	Controller is damaged.	Change the controller
	The handle which control the forward or back is no reset.	Repair or change

If above steps still can not solve problems, please contact after-sales service department of the manufacturer and have the problems solved by specially trained technicians.

## **5.2 Preparation before repair**

To prevent possible accidents during maintenance and repair work, following preparations must be done:

- Park the stacker safely.
- Press the emergency stop switch and disconnect the connectors on accumulator.

## **5.3 Check hydraulic oil level**

- Get the stacker ready for maintenance or repairing.
- Open the cover of electric unit.
- Check hydraulic oil level in oil tank.

Check the hydraulic oil level only after the fork and main frame are lowered to their lowest position.

## **5.4 Use Preparation after maintenance or repairing**

Use the stacker only after following operations have been completed.

- Clean the stacker.
- Check the brake.
- Check the emergency stop switch.
- Check the horn.

**This manual final interpretation retained by manufacturers.**