

Product Description

The type SB4 is a stainless steel beam type load cell with complete hermetic sealing. It is a perfect fit for use in harsh industrial environments.

Application

- Platform scales, hopper and tank scales

Key Features

- Wide range of capacities from 5 kN to 100 kN (510 kg to 10 197 kg)
- Stainless steel construction
- Environmental Protection IP68 with complete hermetic sealing
- Unique blind loading hole
- High input resistance
- Calibration in mV/V/Ω

Options

- OIML approval to C3 MI7.5
- OIML approval to C4 MI7.5 (for 5 ... 50 kN)

Approvals

- OIML approval to C1 (Y = 5 000), C3, C3 MI7.5, C4 and C4 MI7.5 (Y = 11 000)
- NTEP approval to 5 000 intervals, Class III (for 5 kN to 50 kN)
- ATEX hazardous area approval for Zone 0, 1, 2, 20, 21 and 22
- FM hazardous area approval

Packed Weight

■ Capacity (kN)	5–20	50	100
Weight (kg)	1.4	2.9	7.1

Available Accessories

- Compatible range of application hardware
- Compatible range of electronics

Specifications

	(E _{max})	kN	5 / 10 / 20 / 50 / 100				5 / 10 / 20 / 50	
			510 / 1020 / 2039 / 5099 / 10197				510 / 1020 / 2039 / 5099	
Maximum capacity		kg						
Metric equivalents (1 N=0.10197 kg)			(GP)	C1	C3	C3 MI 7.5	C4	C4 MI 7.5
Accuracy class according to OIML R60			n.a.	1 000	3 000		4 000	
Maximum number of verification intervals (n _{max})			n.a.	E _{max} / 5 000	E _{max} / 11 000			
Minimum load cell verification interval (v _{min})			n.a.	E _{max} / 5 000	E _{max} / 11 000			
Temperature effect on minimum dead load output (T _{CO})	%*RO/°10C		≤ ± 0.0400	≤ ± 0.0275	≤ ± 0.0127			
Temperature effect on sensitivity (T _{CR0})	%*RO/°10C		≤ ± 0.0200	≤ ± 0.0160	≤ ± 0.0100		≤ ± 0.0080	
Combined error	%*RO		≤ ± 0.0500	≤ ± 0.0300	≤ ± 0.0200	≤ ± 0.0180	≤ ± 0.0180	≤ ± 0.0150
Non-linearity	%*RO		≤ ± 0.0400	≤ ± 0.0300	≤ ± 0.0166	≤ ± 0.0166	≤ ± 0.0125	≤ ± 0.0125
Hysteresis	%*RO		≤ ± 0.0400	≤ ± 0.0300	≤ ± 0.0166	≤ ± 0.0066	≤ ± 0.0125	≤ ± 0.0066
Creep error (30 minutes) / DR	%*RO		≤ ± 0.0600	≤ ± 0.0490	≤ ± 0.0166	≤ ± 0.0066	≤ ± 0.0125	≤ ± 0.0066
Rated Output (RO)	mV/V		2 ± 0.1%					
Calibration in mV/V/Ω (A...I classified)	%		≤ ± 0.05 (≤ ± 0.005)					
Excitation voltage	V		5...15					
Zero balance	%*RO		≤ ± 5					
Input resistance (R _{LC})	Ω		1 100 ± 50					
Output resistance (R _{out})	Ω		1 000 ± 2					
Insulation resistance (100 V DC)	MΩ		≥ 5 000					
Safe load limit (E _{lim})	%*E _{max}		200					
Ultimate load	%*E _{max}		300					
Safe side load	%*E _{max}		100					
Compensated temperature range	°C		-10...+40					
Operating temperature range	°C		-40...+80 (ATEX -40...+60)					
Load cell material			stainless steel 17-4 PH (1.4548)					
Sealing			complete hermetic sealing; cable entry sealed by glass to metal header					
Protection according EN 60 529			IP68 (up to 2 m water depth) / IP69K					

The limits for Non-Linearity, Hysteresis, and T_{CR0} are typical values.

The sum of Non-linearity, Hysteresis and T_{CR0} meets the requirements according to OIML R60 with p_{LC}=0.7.

Dimensions (in mm)

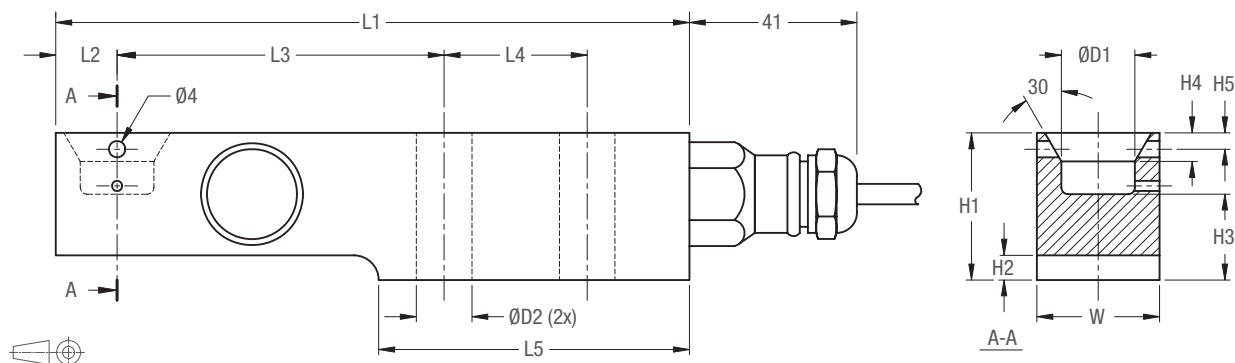

Type	L1	L2	L3	L4	L5	H1	H2	H3	H4	H5	W	D1	D2	Mounting bolts	Torque*
SB4-5/10/20 kN	155	15	80	35	76	36	6	21	7	4	30	18	13	M12 8.8	90 Nm
SB4-50 kN	190	21	105	40	93	49	8	28.5	6	8	43	25	21	M20 8.8	400 Nm
SB4-100 kN	245	30	135	50	120	73	12.5	42	10	n.a.	60	30	27	M24 8.8	700 Nm

* Torque values assume oiled threads.

Wiring

- The load cell is provided with a shielded, 4 conductor cable (AWG 24).
Cable jacket polyurethane
- Cable length: 3 m for SB4-5 kN/10 kN/20 kN
4.5 m for SB4-50 kN/100 kN
- Cable diameter: 5 mm
- On customer enquiry the shield is either floating or connected to the load cell body

